

# **BANDERA COUNTY**

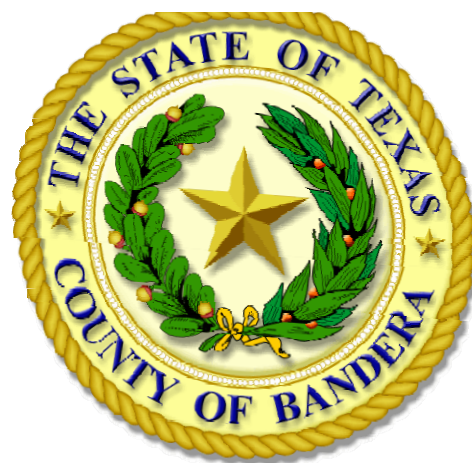

## **Subdivision and Land Development Regulations**

*Adopted By*  
*The Bandera County Commissioners' Court*  
*April 21, 2005*

*Revised November 12, 2015*

*Revised October 27, 2022*

*Revised November 9, 2017*

*Revised July 11, 2019*

*Revised August 25, 2022*

## TABLE OF CONTENTS

<b>1. Preamble</b> .....	1
1.1. Findings.....	1
1.2. Care for Private Property Rights.....	3
1.3. Purpose.....	4
1.4. Enactment.....	6
<b>2. Definitions</b> .....	7
2.1. General Usage.....	7
2.2. Terms.....	7
<b>3. Platting Process</b> .....	11
3.1. General Rules for Platting Land to be Subdivided.....	11
3.2. Sketch Plan.....	11
3.3. Application .....	12
3.4. Preliminary Plan .....	13
3.5. Preliminary Plat.....	14
3.6. Final Plat.....	16
<b>4. Water Availability</b> .....	20
4.1. Applicability.....	20
4.2. Certification of Groundwater Availability for Platting.....	20
4.3. Administrative Information.....	21
4.4. Proposed Subdivision Information.....	21
4.5. Projected Water Demand Estimate.....	22
4.6. General Groundwater Resource Information.....	23
4.7. Obtaining Site-Specific Groundwater Data.....	23
4.8. Determination of Groundwater Quality.....	29
4.9. Determination of Groundwater Availability.....	30
4.10. Groundwater Availability & Usability Statements and Certification.....	31
<b>5. Wastewater</b> .....	33
5.1. Systems Must Meet County Standard.....	33

5.2. Lots Must be Appropriate for Connection.....	33
<b>6. Streets and Drainage.....</b>	<b>34</b>
<b>7. Utilities.....</b>	<b>37</b>
7.1. Construction Guidelines.....	37
7.2. Easements and Liability.....	37
<b>8. Minimum Lot Sizes &amp; Lot Geometry; General &amp; Miscellaneous Requirements.....</b>	<b>38</b>
8.1. Minimum Lot Standards.....	38
8.2. Flag Lots Generally Not Permitted.....	39
8.3. Cattle Guards.....	39
8.4. Subject to Change.....	39
8.5. Tax Certificates Required.....	39
8.6. Deed Restrictions.....	39
8.7. Discharge of Firearms on Small Lots.....	39
8.8. Hunting With Bow And Arrows.....	40
<b>9. Revision of Subdivision Plat.....</b>	<b>41</b>
9.1. Application.....	41
9.2. Notice.....	41
9.3. Grant of Permission.....	41
9.4. Recording Requirements.....	42
<b>10. Construction Bond.....</b>	<b>43</b>
<b>11. Variances.....</b>	<b>44</b>
11.1. Criteria for Variance.....	44
11.2. Application Materials.....	44
11.3. Discretion to Grant Variances.....	44
11.4. Variances as Matter of Record.....	44
<b>12. Enforcement and Penalties.....</b>	<b>45</b>
12.1. Category of Offense.....	45
12.2. Enforcement Actions.....	45
12.3. Enforcement of Plat Notes.....	45
<b>13. Reserved.....</b>	<b>46</b>

**14. Severability** ..... 47  
**INDEX** ..... 48

**APPENDIX**

- A. Manufactured Home Rental Community Rules
- B. Road Standards
- C. Certification of Groundwater Availability
- D. Commissioners Court Signature Block
- E. Tax Affidavit
- F. County Clerk’s Certification
- G. Bandera Electric Cooperative, Inc. – Utility Easement Note
- H. Application for Subdivision Approval
- I. Preliminary Plat Checklist
- J. Final Plat Checklist
- K. Subdivision Process Summary
- L. Regulatory and Permitting Fees
- M. Statement of Under-sized Lot

**ARTICLE ONE: PREAMBLE**  
**REGULATIONS GOVERNING SUBDIVISIONS**  
**IN BANDERA COUNTY**

**1.1. Findings**

- 1.1.1. The Commissioners' Court of Bandera County, having reviewed the best available evidence and having consulted with a select committee of citizens who have studied the issue at the County's request, and also having heard open public testimony, finds that:
- a. The Commissioners' Court has the authority and obligation under state law to enact certain measures related to the subdivision and development of land in order to safeguard the general public health, safety, and welfare of the citizens of Bandera County, and to ensure the moral, orderly and healthful development of the County;
  - b. The current Orders under which the County is operating are inadequate to meet the changing needs of the County, and do not take into account the latest changes in state law affecting Bandera County;
  - c. Bandera County is located near one of the state's major urban areas – the San Antonio Metropolitan Statistical Area – and has experienced rapid population growth, as well as rising demands on limited water supplies and other resources, during the past decade;
  - d. United States Census Bureau figures show that Bandera County grew in population by more than 67 percent between 1990 and 2000 census, a benchmark recognized by the state legislature as a sign of significant growth stress;
  - e. Demographic studies prepared by the Texas State Data Center, and by other reputable sources, predict continued rapid land development and population growth for the San Antonio Metropolitan Area, and for adjacent and nearby counties, especially those such as Bandera which offer Hill Country vistas and an attractive lifestyle;
  - f. Rapid population growth and development have caused both economic and environmental problems in other counties and communities in Texas, and – without reasonable regulations to manage development and the subdivision of land – would

be likely to do the same in Bandera County, straining County roads and other public infrastructure, devaluing existing property, imposing an unwarranted tax burden on the citizens of the County, threatening water supplies and other natural resources, endangering the natural scenic beauty of the County, and generally imposing an adverse risk on the public health and safety;

- g. A number of studies and reports – including (but not limited to) a study at the University of Texas School of Architecture, Community and Regional Planning (*Managing Growth Pressures in Unincorporated Texas: Problems and Options for Change*, by Dr. Robert Paterson and Schleen Johnson, 1998) – document the special need for reasonable regulation of subdivision and development in rural and suburban areas such as Bandera County; also, case studies compiled by the Texas Association of Counties and the Conference of Urban Counties, and interim reports, committee reports, and committee testimony in the Texas State Legislature, support these findings;
- h. In recognition of the important public health and safety challenges faced by developing counties, the Texas Legislature and various state agencies have acted repeatedly to provide for and refine the authority of Texas counties to address the regulation of subdivision and development activity;
- i. The Bandera County Commissioners’ Court needs a unified and effective Court order in place to efficiently implement and enforce the powers and obligations conveyed under these laws of the state, and of the United States, including (but not necessarily limited to) the citations noted below:
  - The Texas Local Government Code (Chapters 81, 232, 233, 235, 240, 412, 422, and others);
  - The Texas Government Code (Chapters 261, 263, 280, 301, 331);
  - The Texas Health and Safety Code (Chapters 121, 122, 341, 361, 364-366);
  - The Texas Transportation Code (Chapters 251 and 396);
  - The Texas Utilities Code (Chapter 181);
  - The Texas Water Code (Chapters 16, 26 and 35);

- Various federal codes and administrative rulings related to flood and emergency management, and environmental guardianship;
- j. Recognizing the particular challenges faced by rapidly growing counties adjacent to urban areas, the Texas Legislature acted in 2003 to extend certain rights to govern infrastructure planning and to promote orderly, moral and healthful development to certain counties, including Bandera County, clarifying the state's interest in reasonable management of growth at the county level, especially in high-growth counties;
  - k. Bandera County residents rely on groundwater as their primary source of drinking water; this water is limited, and both its quality and quantity may be affected by Subdivision and development;
  - l. In recognition of its dependence on limited groundwater resources, and of its arid climate, the State of Texas has declared Bandera County to be a Priority Groundwater Management Area; and,
  - m. Bandera County was the first county in Texas to exercise the authority granted Texas Counties pursuant to Article 35.019, Texas Water Code;
  - n. The future well being and prosperity of Bandera County demands that the County adopt an Order providing for a thorough set of rules and Regulations for the subdivision and development of land, in order to help preserve and protect the public health, safety, morals, financial resources, and the private property interests of the County and its citizens, as well as the natural resources of the County.
- 1.1.2. The Commissioners' Court of Bandera County, following due public notice, investigation, consultation with professional engineers and planners, and open public hearing with its citizens, has declared and hereby declares these Regulations to be necessary and appropriate to respond to the Findings enumerated above.

## **1.2. Care for Private Property Rights**

- 1.2.1. Bandera County Commissioners' Court believes in the right of landowners to have fair and reasonable use of their land;
- 1.2.2. Bandera County seeks to protect private real property rights and property values, while balancing community needs and public health and safety;

- 1.2.3. Bandera County has consulted with a private, professional land planning and engineering firm during the preparation of these rules in order to help ensure that these rules and regulations are based on modern and reasonable professional standards that will not impede economic development or fair land use in the County;
- 1.2.4. The Commissioners' Court has considered the potential burden of these Rules to property owners and taxpayers, and has further considered the potential burden to property owners and taxpayers of substandard development, poor quality roads, flooding, and immoral and unhealthful development that might reasonably be expected to occur in the absence of these Rules;
- 1.2.5. These Rules include a process for appeal and the granting of variances, so that landowners who believe they might be deprived of the fair and lawful use of their land may present their case to the Commissioners' Court; and,
- 1.2.6. The Commissioners' Court believes that these Rules, attached to this Preamble, will on balance protect the property values and property rights of Bandera County citizens and landowners as the County grows and develops.

### **1.3. Purpose**

- 1.3.1. The purpose of this Court Order (these Rules) is to provide for the orderly, moral and healthful development of Bandera County, and for the safety, health and well being of the general public. By establishing procedures for the efficient and orderly subdivision and development of land within its unincorporated areas, Bandera County intends to help maintain the quality of life its citizens have come to expect – and to preserve the natural resources of the County for future generations – without imposing undue burden on current taxpayers and citizens. This Order (these Rules) replace and supersede all prior Orders and rules adopted by this Court relating to the regulation of subdivisions and development in Bandera County.
- 1.3.2. The provisions of this Order apply to the owners and/or agents for any tract of land in Bandera County that is subdivided or resubdivided; or where public improvements are laid out as part of a subdivision process (such as streets, drainage ways, public utility easements, parks, and so on); or where on-site wastewater systems are to be installed; or



where water systems subject to County review are to be created or built; or where other development subject to County permitting – such as building in the Flood Plain, or the creation of a Manufactured Home Rental Community – is to occur. A “Subdivision” is defined in Article Two, “Definitions,” in these Rules.

- 1.3.3. Owners subdividing or re-subdividing property in Bandera County should familiarize themselves with the rules for sanitation and avoidance of water, air, or other types of pollution under Article 447-1 of Vernon’s Texas Civil Statutes.
- 1.3.4. These Rules govern the unincorporated areas of Bandera County and hold no force inside corporate city limits except where there is an interlocal agreement in place between the County and a particular city.
- 1.3.5. Inter local agreement has been executed by Bandera County and City of Bandera. For land within an unincorporated area of the County and also within the extra-territorial jurisdiction of a city (the ETJ), Applicants will be subject to County regulation, and should consult with the County Engineer to determine which rules apply. It is the goal of Bandera County to work with local cities under state law to clarify and streamline overlapping subdivision review and specifications in ETJs.
- 1.3.6. The Commissioners’ Court, other elected officials, and the staff of Bandera County who deal with subdivision and development applications, will assist individuals, builders and developers in understanding the goals and performance standards outlined in this Order and the associated Rules.
- 1.3.7. In specific cases where strict, literal interpretation of the Rules would work undue and unfair hardship on landowners, then a variance may be sought, provided that the overall goals and standards for healthful development in these Rules are substantially met (See the section titled, “Variances,” for more information). Variances may not be assumed or implied. Variances may only be granted by the Commissioners’ Court, acting on a formal agenda item. In all other circumstances, all parties subject to these Rules are expected to abide by them, and the Commissioners’ Court and/or the County Attorney will take

Whatever legal action is necessary to ensure compliance. If any questions arise as to the interpretation of the language in any sections, the Commissioners' Court of Bandera County, or its designated agent, will be the final authority.

- 1.3.8. These Rules are in no way intended to stop subdivision or development activity in Bandera County. The Commissioners' Court hopes these Rules will provide a foundation for successful development that enables people to use their land in ways that are profitable and personally satisfying, while protecting the infrastructure and finances of the county, the water, natural resources, and general healthful environment of the community, and preserving the safety, setting, and character, that has made Bandera County a desirable place to live and own land.

#### **1.4. Enactment**

- 1.4.1. In consideration of the Findings, this Order was presented and passed in Commissioners' Court on the 21<sup>st</sup> day of April, 2005.
- 1.4.2. The Commissioners' Court, the other elected officials, and the staff of Bandera County stand ready to assist Applicants in understanding and abiding by these Rules.

## ARTICLE TWO: DEFINITIONS

### 2.1. General Usage

2.1.1. The following words and terms, when used in this chapter, shall have the following meanings, unless the context clearly indicates otherwise. If a word or term used in this chapter is not contained in this section, it shall have the plain, ordinary and generally accepted meaning.

### 2.2. Terms

- 2.2.1. **Application** – A county-provided form completed by an applicant and accompanied by multiple prints of plans or plats and by support documents as required by these regulations.
- 2.2.2. **Applicant** – A person, partnership, corporation, government, or any other entity intending to subdivide or develop land subject to these Rules.
- 2.2.3. **Aquifer** – A geologic formation, group of formations, or part of a formation that contains water in its voids or pores and may be used as a source of water supply.
- 2.2.4. **Aquifer Test** – A test involving the withdrawal of measured quantities of water from or addition of water to a well and the measurement of resulting changes in water level in the aquifer both during and after the period of discharge or addition for the purpose of determining the characteristics of the aquifer. For the purposes of this chapter, bail and slug tests are not considered to be aquifer tests.
- 2.2.5. **BCRAGD** – Bandera County River Authority And Groundwater District
- 2.2.6. **Bond** – A guarantee of performance including but not limited to a cash deposit, surety bond, or letter of credit, in an amount and form acceptable to the County.
- 2.2.7. **Certification** – A written statement of best professional judgment or opinion as attested to on the Certification of Groundwater Availability for Platting Form contained under §230.3(c) of this title (relating to Certification of Groundwater Availability for Platting).
- 2.2.8. **County** – The county government of Bandera County, Texas.
- 2.2.9. **Designated Agent** – A person designated by the Bandera County Commissioners' Court to implement, or review compliance, with certain parts of these Rules.
- 2.2.10. **Drinking Water Standards** – See Requirements Applicable to Public Water Systems

- 2.2.11. **ETJ** – The extraterritorial jurisdiction of a municipality as determined in accordance with Chapter 42 of the Local Government Code.
- 2.2.12. **Flag Lot** – A lot having the minimum required frontage on a public right of way with the largest portion of the lot area connected to the public right of way by a strip, or “flag pole,” which is included in the lot.
- 2.2.13. **Final Plat** – A map with required text that is prepared in accordance with the provisions of this order and applicable statutory and jurisdictional regulations, which map is prepared to be placed on record in the official records of Bandera County.
- 2.2.14. **Full Build-out** – The final expected number of residences, businesses, or other dwellings in the proposed subdivision.
- 2.2.15. **Licensed Professional Engineer** – An engineer who maintains a current license through the Texas Board of Professional Engineers in accordance with its requirements for professional practice.
- 2.2.16. **Order** – The Order of the Commissioners’ Court authorizing and implementing these Rules.
- 2.2.17. **Plat (See Final Plat)**.
- 2.2.18. **Plat Applicant** – The owner or authorized representative seeking approval of a proposed subdivision pursuant to municipal or county authority. (See Applicant.)
- 2.2.19. **Precinct Commissioner** – The member of the Commissioners’ Court who is elected or appointed to represent the Bandera County precinct in which the land proposed for development and subject to this order is located.
- 2.2.20. **Preliminary Plan** – A detailed plan drawn to scale showing boundaries of lots and road right-of-ways. Preliminary plan prepared by registered surveyor or engineer to show feasibility of subdivision and compliance with subdivision regulations.
- 2.2.21. **Preliminary Plat** – A graphic exhibit prepared by a registered surveyor or engineer, in accordance with the provisions of this order, that delineates proposed legal boundaries with topography and schematic street, drainage and utility layout; sets forth text as required by this Order; and demonstrates that the proposed subdivision is feasible and can comply with the objectives and requirements of this Order.
- 2.2.22. **Public Water System** – A system for the provision to the public of water for human consumption through pipes or other constructed conveyances, which includes all uses

described under the State's definition for drinking water. Such a system must have at least 15 service connections or serve at least 25 individuals at least 60 days out of the year. This term includes any collection, treatment, storage, and distribution facilities under the control of the operator of such system and used primarily in connection with such system, and any collection or pretreatment storage facilities not under such control, which are used primarily in connection with such system. Two or more systems with each having a potential to serve less than 15 connections or less than 25 individuals but owned by the same person, firm, or corporation and located on adjacent land will be considered a public water system when the total potential service connections in the combined systems are 15 or greater or if the total number of individuals served by the combined systems total 25 or greater at least 60 days out of the year. Without excluding other meanings of the terms "individual" or "served," an individual shall be deemed to be served by a water system if he lives in, uses as his place of employment, or works in a place to which drinking water is supplied from the system. [30 TAC 290.38(47)]

2.2.23. **Requirements applicable to Public Water Systems** – The requirements in TCEQ rules covering public water systems in Title 30, Texas Administrative Code, Chapter 290, (relating to Rules and Regulations for Public Water Systems).

2.2.24. **Road Specifications** – See **Road Standards**

2.2.25. **Road Standards** – The Bandera County Road Standards adopted by the Commissioners' Court on December 28, 2000.

2.2.26. **Rules** – When capitalized, refers to the Bandera County Subdivision and Development Rules, and the related regulations and Court Orders.

2.2.27. **Sketch Plan** – A map showing a potential subdivision of land not required to be drawn with precision, to serve as the basis for comments by the County to a landowner or potential applicant regarding general compliance with these regulations.

2.2.28. **Subdivision** – The division of a tract of land into 2 or more lots or tracts for the purpose of transfer of ownership, building or development or, if a new street is involved, any division of a tract of land. Subdivision includes “resubdivision,” as used herein, and shall include any further division of a lot, tract or parcel of land, previously subdivided, for sale, use or other purposes which varies from the latest approved plat of the same. It is the intention of the Commissioners' Court that these Rules shall apply to all acts of

division not excepted by the Local Government Code in Section 232.0015, Exceptions to Plat Requirements.

2.2.29. **Surveyor** – A Registered Professional Land Surveyor certified by the Texas Board of Professional Land Surveying.

2.2.30. **TAC** – Texas Administrative Code

2.2.31. **TCEQ** – Texas Commission on Environmental Quality (formerly Texas Natural Resources Conservation Commission – TNRCC).

2.2.32. **30 TAC** – Title 30, Texas Administrative Code

## ARTICLE THREE: PLATTING PROCESS

### 3.1. General Rules for Platting Land To Be Subdivided

- 3.1.1. Owners wishing to Subdivide (See “Subdivision” under Article Two of these rules for a definition and explanation of what constitutes a subdivision of land) in Bandera County must first submit an Application to the County.
- 3.1.2. An application may be obtained from the County Engineer’s office.
- 3.1.3. The Platting process consists of five stages. These are detailed later in this Article. They are:
  1. Sketch Plan; (optional)
  2. Plat Application;
  3. Preliminary Plan;
  4. Preliminary Plat;
  5. Final Plat.
- 3.1.4 Submittal, review and consideration of the Preliminary Plan, Preliminary Plat and Final Plat shall be consecutive, not concurrent, and shall be considered by Commissioners Court during separate meetings. Not more than one of the required stages shall be considered at the same meeting of the Commissioners Court.

### 3.2. Sketch Plan

- 3.2.1. An Applicant or Potential Applicant who wishes to Subdivide (See definition in Article Two to understand whether a proposed land use or development constitutes a legal Subdivision), may submit a sketch plan. The owner or owner’s representative should develop a plan in sketch form and submit seven (7) blackline copies to the County Engineer not less than ten (10) days prior to the regular meeting of the Commissioners’ Court. The Court will review the Sketch Plan and will discuss with the Applicant the results of the review.
- 3.2.2. If the proposed use or development constitutes a Subdivision, the Court will provide the Applicant with a general sense of whether the Sketch Plan is in general conformance with the underlying principles of these Rules. Since there are no requirements established by these Rules for the content of a Sketch Plan, the Court will comment on the Sketch Plan at a level of detail corresponding to the detail that the Applicant chooses to present in the

- Sketch Plan. The Sketch Plan will not be approved or disapproved but will be noted in the minutes of the Court as received, along with comments that members of Commissioners Court want recorded.
- 3.2.3. An Applicant is encouraged to coordinate subdivision planning and engineering of subdivision improvements with the County Engineer. If the contemplated subdivision includes features that are unconventional, innovative or otherwise not addressed by these Rules, an Applicant may discuss those features with the Commissioners' Court. The Court will allow time (the exact amount to be determined at the discretion of the presiding officer) for Applicants who are present to ask questions of the Court concerning the Sketch Plan, and the court will make a good faith effort to inform Applicants, or potential Applicants, about how their Sketch Plan might conform to the Rules, and of any proposed amendments to the Rules that have been advertised and are under imminent consideration.
  - 3.2.4. Receiving of the Sketch Plan does not constitute or imply forthcoming approval of the Preliminary Plan or Preliminary Plat, which must meet the more detailed requirements laid out in these Rules. Rather, the Court's review and comment on the Sketch Plan is intended to aid Applicants in the understanding of local and state regulations in the early stages of their planning, before they commit to the time and expense of extensive professional studies and/or a Subdivision Application. Applicants should be aware that county rules and regulations might be subject to change between the time they submit a Sketch Plan and formal Application for Preliminary Plan approval.
  - 3.2.5. A Sketch Plan should show the entire area of every tract that is wholly or partly included in the proposed subdivision in order to demonstrate that the Plan furthers the efficient and orderly development of the land. Submittal of a Sketch Plan is recommended by the Commissioners Court but is not required. Applicants who wish to may go straight to the Application stage, or a Sketch Plan may be submitted concurrently with a Preliminary Plan. However, Applicants are encouraged to take advantage of the Sketch Plan process to identify regulatory issues before committing to the greater expense of developing a Preliminary Plan and Application.



### **3.3. Application**

3.3.1. The Applicant shall complete the application form for subdivision approval provided by the County Engineer. The Preliminary Plan submittal shall not be deemed complete by the County unless application fees are paid and all required information is provided on the application form or, as appropriate, on supporting documents attached to the form.

### **3.4. Preliminary Plan**

3.4.1. If the Applicant decides to continue with platting after discussing the Sketch Plan with Commissioners Court, the Applicant should submit to the County Engineer an application for Preliminary Plan approval. The application, including seven (7) blackline prints of the plan, shall be submitted not less than thirty (30) days prior to the regular meeting at which the Commissioners Court is asked to consider the application. If the Commissioners Court finds that the plan conforms to the requirements set forth herein, the Court will grant conditional approval, subject to conditions agreed to upon writing.

3.4.2. The Preliminary Plan is to demonstrate that the proposed subdivision is feasible and can comply with the objectives and requirements of this order. The Plan shall be drawn to an appropriate size and scale to accommodate the entire subdivision. Preliminary Plan shall contain the following information:

- a. Boundary lines of: the existing tract(s); existing right of way and easements within or adjoining the area within the Plan; proposed lots, rights of way, utility easements, and drainage easements.
- b. Dimensions of existing road surface adjoining tract and width of existing right-of-way.
- c. The location and dimensions of proposed streets and drainage structures.
- d. Acres within the Preliminary plan.
- e. Scale and north arrow.
- f. An index map locating the subdivision in relation to an intersection of county or state roads.

3.4.3. A Preliminary Plan shall show the entire boundary of every tract that is wholly or partly included in the proposed subdivision. A Preliminary Plan may show proposed phased development of land included within the Plan, with respective phases to be approved in separate Final Plats in accordance with Section 3.4.1. A Preliminary Plan for phased

development shall clearly outline the boundaries of the construction phases and shall state the date by which the Final Plat application for each phase shall be submitted.

- 3.4.4. Preliminary Plan approval shall expire if a complete Application for Preliminary Plat approval is not submitted to the Commissioners' Court within twelve (12) months of the date of Preliminary Plan approval.

### **3.5. Preliminary Plat**

- 3.5.1.** The Applicant should submit to the County Engineer an application for Preliminary Plat approval. The application, including seven (7) blackline prints of the Preliminary Plat, shall be submitted not less than thirty (30) days prior to the regular meeting at which the Commissioners Court is asked to consider the application. If the Commissioners Court find that the Preliminary Plat conforms to the requirements set forth herein, the Court will grant conditional approval, subject to conditions agreed to upon writing. Two (2) copies of the proposed restrictions contemplated by the owner will accompany the Preliminary Plat. The restrictions shall be duly signed and acknowledged by the property owner and any lien holders in the manner required for acknowledgment of deeds. Bandera County shall not be included as a party with standing to enforce restrictions.
- 3.5.2.** The Application for approval of a Preliminary Plat shall be accompanied by a statement from Bandera Electric Cooperative that power lines will be made available to the subdivision.
- 3.5.3.** The Preliminary Plat shall be drawn on one or more sheets measuring 18 inches by 24 inches in size and shall contain the following information:
- a. Boundary lines of: the existing tract(s); existing right of way and easements within or adjoining the area within the Plat; proposed lots, rights of way, utility easements, and drainage easements; adjoining lots or tracts for a distance of 50 feet, with owner name, deed or plat reference as determined by the most recent tax roll; city limits or extraterritorial jurisdiction and county line.
  - b. Bearings and distances of all lot boundaries.
  - c. Schematic layout of existing and proposed public water and sewer lines and facilities such as wells, storage tanks, lift stations, treatment plants, and utility easements.

- d. Existing topography at 5-foot contour intervals (note that smaller intervals might be required for coverage of particular areas for design of street, utility and drainage improvements).
  - e. The location of existing water courses and the limits of the 100-year floodplain, if applicable, as depicted on the latest Flood Insurance Rate Map (FIRM) issued by the Federal Emergency Management Agency, whose panel number and effective date shall be stated on the plat; or a statement that the subdivision contains no designated flood hazard area according to the specified FIRM.
  - f. Dimensions of existing road surface adjoining tract and width of existing right-of-way.
  - g. The location and dimensions of proposed street pavement and drainage structures.
  - h. Lot letters, block numbers, street names and deed or plat reference for existing easements.
  - i. Acres within the Preliminary Plat, and the area and identification of all lots.
  - j. Standard notes, certifications and text as required by this order.
  - k. Scale, north arrow, and addresses of the owner of record, subdivider, surveyor and engineer.
  - l. A map locating the subdivision in relation to an intersection of county or state roads and, if the plat drawing is on more than one page, a key map.
- 3.5.4. Owners' and any lien holders' dedication statements and restrictions shall be duly signed and acknowledged by the property owners and any lien holders in the manner required for acknowledgment of deeds.
- 3.5.5. A Preliminary Plat shall show the entire boundary of every tract that is included in the proposed subdivision.
- 3.5.6. The Preliminary Plat shall be drawn to a scale of not more than two hundred (200) feet per inch and certified as to accuracy by the engineer or surveyor who prepared the plat from actual survey on the ground.
- 3.5.7. Preliminary Plat approval shall expire if a complete Application for Final Plat approval is not submitted to the Commissioners' Court within twelve (12) months of the date of Preliminary Plat approval; or, in the case of phased development, Preliminary Plat approval shall expire if a complete Application for Final Plat approval for any phase of

the subdivision is not submitted to the Commissioners' Court by the date specified for that phase on the Preliminary Plan.

- 3.5.8. A Preliminary Plat must be submitted to the Commissioners Court signed by each owner (including lien holders) of the property to be subdivided.

All proposed road and drainage construction plans are to be submitted to the County Engineer before Preliminary Plat is approved by Commissioners' Court.

### **3.6. Final Plat**

- 3.6.1. The subdivider shall present eight (8) blackline prints of the proposed final plat, one (1) original mylar Final Plats and supporting documents to the Commissioners Court at least 30 days prior to the subdivider requesting approval of the subdivision, accompanied by a statement from Bandera Electric Cooperative that the plat has been reviewed and approved by BEC. Upon final approval, the subdivider then records the approved final plat and other documents, as applicable, with the County Clerk. Upon completion of all requirements precedent to plat recording, the applicant shall submit to the County Engineer: a) one mylar print of the approved Final Plat bearing all required owner, engineer, surveyor and lien holder signatures; b) an electronic file of the Final Plat in a file format acceptable to the County Engineer. Approval of a Final Plat shall expire if the plat is not filed with the Commissioners' Court, in complete and acceptable form for recording and upon completion of all requirements for subdivision improvements as set forth herein, within twelve (12) months from the date of the Commissioners' Court's approval of the Preliminary Plat. It is a violation of these Rules for any person to convey ownership of a lot prior to the recording of a Final Plat in the Official Records of Bandera County.
- 3.6.2. The Final Plat shall be drawn to a scale of not more than two hundred (200) feet per inch and certified as to accuracy by the engineer or surveyor who prepared the plat from an on-the-ground survey. A corner of the subdivision shall be tied (by bearing and distance) to an original survey corner and shown on the plat.
- 3.6.3. The Final Plat shall be on one or more sheets measuring 18 inches by 24 inches in size. A key map showing the entire area shall be drawn on the first sheet and on a U.S. Geological Survey map on a scale of 1" = 2000'.
- 3.6.4. The name of the proposed subdivision or any of the physical features (such as streets, parks, etc.) must not be so similar in spelling or in pronunciation to the names of any

- similar features in Bandera County, or in any incorporated town or city therein, as to cause confusion. Streets that are a continuation of an existing street, or which the Commissioners Court finds to be a reasonable extension of an existing street within 1,000 feet, shall take the name of that existing street. Street naming and property numbering procedures shall be established in accordance with the platting and subdivision requirements of Bandera County. A duplicate street, a street that can be defined as a street that has the same name as another street and matches the description in one or more of the following cases will not be allowed:
- Street name sound alike.
  - Street name is plural.
  - Street names are the same yet has a number or letter suffix.
- 3.6.5. The initial expense of street sign placement in new development areas shall be the responsibility of the developer. Location and type of said signs shall be approved by Bandera County Engineer as part of acceptance of the subdivision plat.
- 3.6.6. Lot numbers will be assigned to each new lot; tract or building site on the original drawings of a Final Plat, mobile (manufactured) home park plan, planned unit development or any other plan requiring the approval of the Bandera County Commissioners Court.
- 3.6.7. Boundary lines and lot lines shall be shown by bearings and distances. The subdivision shall be described in relation to established surveys and shall be located with respect to an original corner of the original survey of which it is a part. All property lines intersecting roads or streets will end at the intersecting line of the R.O.W. of such road or street. No property line can be extended to the center of the road.
- 3.6.8. All block corners and angles in streets and alleys shall be marked with ½” iron rods or with an appropriate concrete or other type marker approved by the Commissioners’ Court. All proposed road and drainage construction plans are to be approved by the County Engineer before Final Plat is approved by Commissioners’ Court. A high and low elevation for each lot or tract located in flood prone areas will be determined and indexed by lot or tract number. This index may be on the first sheet, or on sheets, which show the lots or tracts. All elevations will be recorded in feet and tenths of feet above mean sea level.

- 3.6.9. Unconventional layouts, or layouts that will cause unsatisfactory drainage conditions, or that will complicate maintenance of streets, or any land dedicated for public use, will not be accepted.
- 3.6.10. Lot and block numbers and street names are to be arranged in a systematic order in accordance with the Bandera County Rural Addressing Plan and shown on the plat and on the ground in distinct and legible figures and letters. No roads, streets, or lots will be accepted without names or numbers shown on the plat and on the ground. All naming or numbering of streets, roads or lots will be coordinated, approved and/or assigned by the County Commissioners Court prior to use or plat is accepted.
- 3.6.11. Locations or lots, streets, alleys, parks, utility easements and other features must be shown with accurate dimensions in feet and decimals of feet. Length of radius and length of all curves, with bearings of all tangents, shall be shown. Dimensions from all angle points of curve to lot lines shall also be shown. These must be on the final plat before it is accepted and recorded.
- 3.6.12. A certificate of dedication, duly acknowledged, of all streets, alleys, parks, playgrounds, and other land intended for public use forever shall be a part of the plat.
- 3.6.13. Appropriate dedication for public utilities not less than 20 feet wide must be provided where needed, either by absolute dedication, or by dedication of easement. No structure shall inhibit unrestricted passage in utility easements and must be maintained at all times. All such easements will be accurately shown. A sample utility easement can be obtained in the County Engineer's office or at the Bandera Electric Cooperative.
- 3.6.14. Reference must be made to the original patented survey and the number of acres in each survey with the abstract number of same and reference made to the volume and page in the Deed Records of the tract being subdivided. Reference must also be made to the number of acres in each survey, with abstract number of same for all dedicated areas. Show the number of acres in all areas where roads are dedicated for the public use. Show number of linear feet of roads. Show total number of lots or tracts.
- 3.6.15. All lots shall show the acreage contained therein. All lots or tracts situated in more than one survey must have shown the number of acres in each survey contained in that tract or lot.

3.6.16. The Final Plat shall include on its face in legible style and size Commissioners, Court signature block as shown in Appendix D-1 and the County Clerk Certification as shown in Appendix F-2 of these Rules.

3.6.17. There shall be a permanent sign erected at the subdivision entrance at the county road or the state highway, with the name of the subdivision.

3.6.18. A subdivision may be platted and developed in phases.

3.6.19. Final Plat approval does not indicate acceptance of roads for county maintenance.

3.6.20. Filing and recording fees for subdivision plats in Bandera County:

Current land development and permitting fees are available from the office of the County Engineer. Current filing, recordation and document handling fees are available from the office of the County Clerk.

These fees shall be payable to the County Clerk at the time of filing the final plat.

3.6.21. The following statement shall appear conspicuously on all final plats:

"Bandera County and the Bandera County River Authority and Groundwater District make no representation or guarantee as to water quality or that a present or future adequate water supply exists."

3.6.22. The following statements shall appear conspicuously on any plat containing private streets, roads, drives, emergency access easements, recreation areas and open spaces:

"Bandera County shall not be responsible for maintenance of private streets, drives, emergency access easements, recreation areas and open spaces; the property owners in this subdivision shall be responsible for the maintenance of private streets, roads, drives, emergency access easements, recreation areas and open spaces, and said owners agree to indemnify and save harmless Bandera County from all claims, damages and losses arising out of or resulting from performance of obligations of said owners set forth in this paragraph."

STATE OF TEXAS            )  
COUNTY OF BANDERA    )(

KNOW ALL MEN BY THESE PRESENTS:

THE OWNER OF LAND SHOWN ON THIS PLAT DESIGNATED AS \_\_\_\_\_ SUBDIVISION IN BANDERA COUNTY, TEXAS AND WHOSE NAME IS SUBSCRIBED HERETO, DOES HEREBY SUBDIVIDE SUCH PROPERTY AS SHOWN HEREON AND DEDICATES ALL THE PRIVATE ROADS FOR THE USE OF THE LANDOWNERS, THEIR HEIRS, ASSIGNS, ETC. AND THEY SHALL REMAIN PRIVATE. THE MAINTENANCE OF THE ROADS SHALL BE THE RESPONSIBILITY OF THE DEVELOPER UNTIL SUCH TIME A NON PROFIT HOMEOWNER'S ASSOCIATION (HOA), ETC. IS ESTABLISHED, AND THAT THE ROADS SHALL REMAIN PRIVATE AND WILL NEVER BE ELIGIBLE FOR COUNTY MAINTENANCE. FURTHERMORE, THE OWNER DOES HEREBY DEDICATE TO THE PUBLIC, THE PUBLIC UTILITY AND DRAINAGE EASEMENTS FOR THE PURPOSES SHOWN HEREON.

BY: OWNER  
TITLE

## **ARTICLE FOUR: WATER AVAILABILITY**

### **4.1. Applicability**

- 4.1.1. The County shall require certification that adequate groundwater is available for a proposed Subdivision if groundwater under that land is to be the source of water supply.
- 4.1.2. The Applicant and the Texas licensed professional engineer or Texas Licensed professional geoscientist shall use this Article and the attached form to certify that adequate groundwater is available under the land of a proposed Subdivision. These rules do not replace other state and federal requirements applicable to public drinking water supply systems.

### **4.2. Certification of Groundwater Availability for Platting**

- 4.2.1. Certification. A Texas licensed professional engineer or Texas licensed professional geoscientist must prepare the certification required by this chapter.
- 4.2.2. Submission information. The plat applicant shall provide to the county authority the certification adequacy of groundwater under the subdivision required by this Article.
- 4.2.3. This Article and the following form with supporting documents as described in 4.5 thru 4.10 and required Appendix C, Certification Of Groundwater Availability For Platting Form, shall be used and completed if plat applicants are required by the county authority to certify that adequate groundwater is available under the land to be subdivided. Commissioners' Court may from time to time make changes to this form that does not conflict with the requirements of the rules.
- 4.2.4. In conformance with state rules, if an Applicant submits a plat for the subdivision of a tract of land for which the source of the water supply intended for the subdivision is ground water under that land, the Preliminary Plat application shall have attached to it a form with all attachments and a statement that :
  - a) is prepared by a Texas licensed professional engineer or Texas licensed professional geoscientist.
  - b) certifies that adequate groundwater is available for the subdivision.



4.2.5. Upon receipt of the Texas Commission On Environmental Quality Certification of Groundwater Availability for Platting Form, the County shall deliver a copy of said completed form and attachments to Bandera County River Authority And Groundwater District, for review, comment and BCRA GD recommendations prior to final approval of the subdivision plat by Commissioners' Court. Bandera County relies on the comments and recommendations of BCRA GD on water availability in a subdivision prior to considering granting final approval for the subdivision plat.

### **4.3. Administrative Information**

4.3.1. At a minimum, the following general administrative information shall be provided for a proposed Subdivision for which groundwater is the source of water supply:

- the name of the proposed subdivision;
- any previous owners or names which identifies the tract of land;
- the name, address, phone number, and facsimile number of the property owner or owners;
- the name address phone number, and facsimile number of the person submitting the plat application;
- the name, address, phone number, facsimile number and registration number of the licensed professional engineer or licensed professional geoscientist preparing the certification as required in this chapter;
- the location and legal description of the proposed property; and subdivision;
- the tax assessor parcel control number.

### **4.4. Proposed Subdivision Information**

4.4.1. The following information pertaining to the proposed Subdivision shall be provided, as specified by the state in Chapter 230 of Title 30, Texas Administrative Code (30 TAC 230) and Water Code – Chapter 35 Section 35.109. Water Availability. (a) The commissioners court of a county in a groundwater management area may adopt water availability requirements in an area where platting is required if the court determines that the requirements are necessary to prevent or projected water use in the county from exceeding the safe sustainable yield of the county's water supply.

- a) the purpose of the proposed subdivision – for example, single family residential, multi-family residential, non-residential, commercial, or industrial;
- b) the size of the proposed subdivision in acres;
- c) the number of proposed lots within the proposed subdivision;
- d) the average size (in acres) of the proposed lots in the proposed subdivision;

- e) the anticipated method of water distribution to the proposed lots in the proposed subdivision including, but not limited to:
  - e-1) an expansion of an existing public water supply system to serve the proposed subdivision (if groundwater under the subdivision is to be the source of water supply);
  - e-2) a new public water supply system for the proposed subdivision;
  - e-3) individual water wells to serve individual lots; or,
  - e-4) a combination of methods;
- f) if the anticipated method of water distribution for the proposed subdivision is from an expansion of an existing public water supply system or from a proposed public water supply system, evidence required under §290.39(c)(1) of 30 TAC (relating to Rules and Regulations for Public Water Systems) which shall be provided demonstrating that written application for service was made to the existing water providers within a ½-mile radius of the subdivision.

#### **4.5. Projected Water Demand Estimate**

- 4.5.1. Residential water demand estimate. Residential water demand estimates at full build out shall be provided as specified in §230.3(c) of 30 TAC (relating to Certification of Groundwater Availability for Platting). Residential demand estimates shall, at a minimum be based on the current demand of any existing residential well including those identified under §230.8(b) of 30 TAC (relating to Obtaining Site-Specific Groundwater Data), or §290.41(c) of 30 TAC (relating to Rules and Regulations for Public Water Systems), and:
  - a) the number of proposed housing units at full build out;
  - b) the average number of persons per housing unit;
  - c) the gallons of water required per person per day;
  - d) the water demand per housing unit per year (acre feet per year); and
  - e) the total expected residential water demand per year for the proposed subdivision (acre per feet per year).
- 4.5.2. Non-residential water demand estimate. Water demand estimates at full building out shall be provided for all non-residential uses as specified in §230.3(c) of 30 TAC. Non-residential uses shall be specified by type of use and groundwater demand per year (acre

feet per year) for each type of use. The estimate shall also include the existing non-residential demand of any well including those identified under §230.8(b) of 30 TAC or §290.41(c) of TAC.

4.5.3. Total annual water demand estimate. An estimate of the total expected annual groundwater demand, including residential and non-residential estimates at full build out (acre feet per year), shall be provided as specified in §230.3(c) of 30 TAC.

4.5.4. Submission of information. The sources of information used and calculations performed to determine the groundwater demand estimates as required by this section shall be made available to the county authority if requested. The plat applicant shall provide any additional groundwater demand information required by the county authority as part of the plat application.

#### **4.6. General Groundwater Resource Information**

4.6.1. Aquifer identification. Using Texas Water Development Board aquifer names, the aquifer(s) underlying the proposed subdivision which is planned to be used as the source of water for the subdivision shall be identified and generally described as specified in §230.3(c) of 30 TAC (relating to Certification of Groundwater Availability for Platting).

4.6.2. Geologic and groundwater information. To meet the requirements of this chapter, the following geologic and groundwater information shall be considered in planning and designing the aquifer test under §230.8(c) of 30 TAC (relating to Obtaining Site-Specific Groundwater Data):

- a) the stratigraphy of the geologic formations underlying the subdivision;
- b) the lithology of the geologic strata;
- c) the geologic structure;
- d) the characteristics of the aquifer(s) and their hydraulic relationships;
- e) the recharge to the aquifer(s), and movement and discharge of groundwater from the aquifer(s); and,
- f) the ambient quality of water in the aquifer(s).

#### **4.7. Obtaining Site-Specific Groundwater Data**

4.7.1. Applicability of Section. This section is applicable to all proposed Subdivisions with individual water wells on individual lots and proposed subdivisions with new public water supply systems or an expansion of an existing public water system. For

subdivisions with a proposed public water system or expansion of an existing public water system, site specific groundwater data shall developed under the requirements of Chapter 290, Subchapter D of 30 TAC (relating to Rules and Regulations for Public Water Systems) and the information developed to meet these requirements shall be attached to the form required under §230.3 of 30 TAC (relating to Certification of Groundwater Availability for Platting) in addition to information required in this section.

4.7.2. Location of existing wells. All known existing, abandoned, and inoperative wells within the proposed subdivision shall be identified, located, and mapped by on-site surveys. Existing well locations shall be illustrated on the plat required by the municipal or county authority.

4.7.3. Aquifer testing. Utilizing the information considered under §230.7(b) of 30 TAC (relating to General Groundwater Resource Information), an aquifer test shall be conducted to characterize the aquifer(s) underlying the proposed subdivision. The aquifer test must provide sufficient information to allow evaluation of each aquifer that is being considered as a source of residential and non-residential water supply for the proposed subdivision. Appropriate aquifer testing shall be based on typical well completions. An aquifer test conducted under this section utilizing established methods shall be reported as specified in §230.3(c) of 30 TAC and shall include, but not be limited to the following items:

a) Test well and observation well(s). For proposed subdivisions with or without a proposed public water system, at a minimum, one test well (i.e., pumping well) and one observation well, shall be required to conduct an adequate aquifer test under this section. For proposed subdivisions with individual water wells on individual lots over 100 acres, test wells and additional observation well(s) shall be completed in the same aquifer or aquifer production zone for each 100 acres. The locations of the test and observation well(s) shall be shown on the plat required by the county authority. Commissioners' Court may grant a variance from this requirement if the applicant demonstrates fewer wells are needed for the evaluation.

- b) Location of wells. The test and observation well(s) must be placed within the proposed subdivision and shall be located by latitude and longitude. The observation well(s) shall be located at a radial distance such that the time-drawdown data collected during the planned pumping period fall on a type curve of unique curvature. In general, observation wells in unconfined aquifers should be placed no farther than 300 feet from the test well, and no farther than 700 feet in thick, confined aquifers. The observation well should also be placed no closer to the test well than two times the thickness of the aquifer's production zone. The optimal location for the observation well(s) can be determined by best professional judgment after completion and evaluation of the test well as provided in paragraph (4) of this subsection.
- c) Lithologic and geophysical logs. The test and observation wells shall be lithologically and geophysically logged to map and characterize the geologic formation(s) and the aquifer(s) in which the aquifer test(s) is to be performed.
  - c-1) A lithologic log shall be prepared showing the depth of the strata, their thickness and lithology (including size, range, and shape of constituent particles as well as smoothness), occurrence of water bearing strata, and any other special notes that are relevant to the drilling process to the understanding of subsurface conditions.
  - c-2) Geophysical logs shall be prepared which provide qualitative information on aquifer characteristics and groundwater quality. At a minimum, the geophysical logs shall include an electrical log with shallow and deep-investigative curves (e.g., 16-inch short normal/64-inch long normal resistivity curves or induction log) with a spontaneous potential curve and a gamma-ray log.
  - c-3) The county authority may, on a case-by-case basis, waive the requirement of geophysical logs as required under this section if it can be adequately demonstrated that the logs are not necessary to characterize the aquifer(s) for testing purposes.

- d) Well development and performance. The test and observation well(s) shall be developed prior to conducting the aquifer test to repair damage done to the aquifer(s) during the drilling operation. Development shall insure that the hydraulic properties of the aquifer(s) are restored as much as practical to their natural taste.
- d-1) Well development procedures applied to the well(s) may vary depending on the drilling method used and the extent of the damage done to the aquifer(s).
- d-2) During well development, the test well shall be pumped for several hours to determine the specific capacity of the well, the maximum anticipated drawdown, the volume of water produced at certain pump speeds and drawdown, and to determine if the observation well(s) are suitably located to provide useful data.
- d-3) Water pumped out of the well during well development shall not be allowed to influence initial well performance results.
- d-4) Aquifer testing required by this section shall be performed before any acidization or other flow-capacity enhancement procedures are applied to the test well.
- e) Protection of groundwater. All reasonably necessary precautions shall be taken during construction of test and observation wells to ensure that surface contaminants do not reach the subsurface environment and that undesirable groundwater (water that is injurious to human health and the environment or water that can cause pollution to land or other waters) if encountered, is sealed off and confined to the zone(s) of origin.
- f) Duration of aquifer test and recovery. The duration of the aquifer test depends entirely on local and geologic conditions. However, the test shall be of sufficient duration to observe a straight-line trend on a plot of water level versus the logarithm of time pumped. Water pumped during the test shall not be allowed to influence the test results. Aquifer testing shall not commence

until water levels (after well development) have completely recovered to their pre-development level or at least to 90% of that level.

f-1) At a minimum, a 24-hour uniform rate aquifer test shall be conducted. Testing shall continue long enough to observe a straight-line trend on a plot of water level versus the logarithm of time pumped. If necessary, the duration of the test should be extended beyond the 24-hour minimum limit until the straight-line trend is observed.

- If it is impractical to continue the test until a straight-line trend of water level versus the logarithm of time pumped is observed within the 24-hour limit, the test shall continue at least until a consistent pumping-level trend is observed. In such instances, failure to observe the straight-line trend shall be recorded.
- If the pumping rates remain constant for a period of at least four hours and a straight-line trend is observed on a plot of water level versus the logarithm of time pumped before the 24-hour limit has been reached, the pumping portion of the test may be terminated.

f-2) Water-level recovery data shall be obtained to verify the accuracy of the data obtained during the pumping portion of the test. Recovery measurements shall be initiated immediately at the conclusion of the pumping portion of the aquifer test and shall be recorded with the same frequency as those taken during the pumping portion of the aquifer test. Time-recovery measurements shall continue until the water levels have recovered to pre-pumping levels or at least to 90% of that level. If such recovery is not possible, time-recovery measurements should continue until a consistent trend of recovery is observed.

g) Use of existing wells and aquifer test data.

- g-1) An existing well may be utilized as an observation well under this section if sufficient information is available for that well to demonstrate that it meets the requirements of this section.
- g-2) The county authority may accept the results of a previous aquifer test in lieu of a new test if:
- g-3) The previous test was performed on a well located within a ¼-mile radius of the subdivision;
- g-4) The previous test fully meets all the requirements of this section;
- g-5) The previous test was conducted on an aquifer which is being considered as a source of water supply for the proposed subdivision; and
- g-6) Aquifer conditions (e.g., water levels, gradients, etc.) during the previous test were approximately the same as they are presently.
- h) Need for additional aquifer testing and observation wells. Best professional judgment shall be used to determine if additional observation wells or aquifer tests are needed to adequately demonstrate groundwater availability. The Theis and Cooper-Jacob non-equilibrium equations, and acceptable modifications thereof, are based on well-documented assumptions. To determine if additional information is needed, best professional judgment shall be used to consider these assumptions, the site-specific information derived from the aquifer test required by this section, the size of the proposed subdivision, and the proposed method of water delivery.
- i) Submission of information. The information, data, and calculations required by this section shall be made available to the county authority and BCRA GD, to document the requirements of this section as part of the plat application.
- j) After completion of testing, the test/observation wells shall be plugged or completed as water wells according to BCRA GD rules. One well in the subdivision shall be completed with a minimum of 4-in. casing and dedicated to BCRA GD for a monitoring well. The well must have access from a public road and a minimum of 10-foot radius around the well for operation by the district.



4.8.1. Water quality analysis. Water samples shall be collected near the end of test of the aquifer for chemical analysis. Samples shall be collected from each aquifer being considered for water supply for the proposed Subdivision and reported as specified. For proposed subdivisions where the anticipated method of water delivery is from an expansion of an existing public water supply system or a new public water supply system, the samples shall be submitted for bacterial and chemical analysis as required by Chapter 290, Subchapter F of this title (relating to Drinking Water Standards Governing Drinking Water Quality and Reporting Requirements for Public Water Supply Systems).

a) For proposed subdivisions where the anticipated method of water delivery is from individual water supply wells on individual lots, samples shall be analyzed for the following:

b-1) chloride;

b-2) conductivity;

b-3) fluoride;

b-4) iron;

b-5) nitrate (as nitrogen);

b-6) manganese;

b-7) pH;

b-8) sulfate;

b-9) total hardness;

b-10) total dissolved solids;

b-11) presence/absence of total coliform bacteria;

b-12) calcium;

b-13) carbonate/bicarbonate; and

b-14) magnesium.

c) Conductivity and pH values may be measured in the field, and the other constituents shall be analyzed in a Texas Department of Health approved laboratory using methods approved by the commission.

4.8.2. Submission of Information. The information, data and calculations required by this section shall be made available to the county authority and BCRA GD, to document the requirements of this section as part of the plat applications.

#### **4.9. Determination of Groundwater Availability**

- 4.9.1. Time frame for determination of groundwater availability. At a minimum, both a short- and long-term determination of groundwater availability shall be made, each considering the estimated total water demand at full build out of the proposed Subdivision. Groundwater availability shall be determined for ten years and 30 years and for any other time frame(s) required by the county authority.
- 4.9.2. Other considerations in groundwater availability determination. Groundwater availability determination shall take into account the anticipated method of water delivery as identified under §230.5 of 30 TAC (relating to Proposed Subdivision Information) and will be compared to annual demand estimates at full build out as determined under §230.6 of 30 TAC (relating to Project Water Demand Estimate).
- 4.9.3. Determination of aquifer parameters. The parameters of the aquifer(s) being considered to supply water to the proposed subdivision shall be determined utilizing the information considered under §230.7 of 30 TAC (relating to General Groundwater Resource Information) and data obtained during the aquifer test under §230.8 of 30 TAC (relating to Obtaining Site-Specific Groundwater Data) for individual water wells and/or under Chapter 290, Subchapter D of 30 TAC (relating to Rules and Regulations for Public Water Systems) and reported as specified in §230.3(c) of 30 TAC (relating to Certification of Groundwater Availability for Platting). The time-drawdown and time-recovery data obtained during the aquifer test shall be used to determine aquifer parameters utilizing the non-equilibrium equations developed by Theis or Cooper-Jacob, or acceptable modifications thereof. The following aquifer parameters shall be determined:
- a) rate of yield and drawdown;
  - b) specific capacity;
  - c) efficiency of the pumped (test) well;
  - d) transmissivity;
  - e) coefficient of storage (porosity);
  - f) hydraulic conductivity;

- g) recharge or barrier boundaries, if any are present; and
- h) thickness of the aquifer(s).

4.9.4. Determination of groundwater availability. Using the information and data identified and determined in subsections (b) and (c) of this section, the following calculations shall be made.

- a) Time-drawdown. The amount of drawdown at the pumped well(s) and at the boundaries of the proposed subdivision shall be determined for the time frames identified under subsection (a) of this section.
- b) Distance-drawdown. The distance(s) from the pumped well(s) to the outer edges of the cone(s)-of-depression shall be determined for the time frames identified under subsection (a) of this section.
- c) Well interference. For multiple wells in a proposed subdivision, calculations shall be made to:
  - c-1) determine how pumpage from multiple wells will affect drawdown in individual wells for the time frames identified under subsection (a) of this section; and
  - c-2) determine a recommended minimum spacing limit between individual wells and well yields from the wells that will allow for the continued use of the wells for the time frames identified under subsection (a) of this section.

4.9.5. Determination of groundwater quality. The water quality analysis required under §230.9 of this title (relating to Determination of Groundwater Quality) shall be compared to primary and secondary public drinking water standards and the findings documented as specified in §230.3(c) of 30 TAC.

4.9.6. Submission of information. The information, data, and calculations required by this section shall be made available to the county authority and BCRA GD, to document the requirements of this section as part of the plat application.

#### **4.10. Groundwater Availability and Usability Statements and Certification**

4.10.1. Groundwater availability and usability statements. Based on the information developed under §230.10 of 30 TAC (relating to Determination of Groundwater Availability), the

following information shall be provided as specified in §230.3(c) of 30 TAC (relating to Certification of Groundwater Availability for Platting):

- a) the estimated drawdown of the aquifer at the pumped well(s) over a ten-year period and over a 30-year period;
- b) the estimated drawdown of the aquifer at the subdivision boundary over a ten-year period and over a 30-year period;
- c) the estimated distance from the pumped well(s) to the outer edges of the cone(s)-of-depression over a ten-year period and over a 30-year period;
- d) the recommended minimum spacing limit between wells and the recommended well yield; and
- e) the sufficiency of available groundwater quality to meet the intended use of the platted subdivision.

4.10.2. Groundwater Availability Determination Conditions. The assumptions and uncertainties that are inherent in the determination of groundwater availability should be clearly identified as specified in §230.3(c) 30 TAC. These conditions must be identified to adequately define the bases for the availability and usability statements. These bases may include, but are not limited to, uncontrollable and unknown factors such as:

- a) future pumpage from the aquifer or from interconnected aquifer from area wells outside of the subdivision or any other factor that cannot be predicted that would affect the storage of water in the aquifer,
- b) long-term impacts to the aquifer based on climatic variations,
- c) future impacts to usable groundwater due to unforeseen or unpredictable contamination.

4.10.3. Certification. Based on best professional judgment, current groundwater conditions, and the information developed and presented in the form specified by §230.3(c) of this title, the licensed professional engineer or professional geoscientist certifies by signature, seal and date that adequate groundwater is available from the underlying aquifer(s) to supply the estimated demand of the proposed subdivision.

## **ARTICLE FIVE: WASTEWATER**

### **5.1. Systems Must Meet County Standard**

- 5.1.1. Provisions must be made for the disposal of solid waste that is agreeable to the Commissioners' Court.
- 5.1.2. Proposals will be considered on their individual merit.
- 5.1.3. All septic tanks shall meet State and County regulations and must be permitted and inspected before, during and after construction. All tests will be made by a registered Professional Engineer or registered Professional Sanitarian or individual authorized by the State to perform such function..

### **5.2. Lots Must Be Appropriate for Connection**

- 5.2.1 All structures shall be connected to septic tanks or sewer systems as required by law and conform to the regulations of Bandera county's On-Site Sewage Facility program.
- 5.2.2. The sub-divider shall ascertain and certify that an acceptable OSSF system can be installed on each tract or lot in subdivision unless public sanitary sewer collection facilities are made available to the site.
- 5.2.3. A statement of availability of electric power will be obtained from Bandera Electric Cooperative and will be submitted prior to any septic tank permits being used.
- 5.2.4. No Subdivisions, nor Subdivision Lots, shall use unapproved outdoor toilets or cesspools.

## ARTICLE SIX: STREETS AND DRAINAGE

- 6.1.** In addition to the standards detailed in this article, Subdividers must conform to the Road and Drainage Specifications and the Flood Damage Prevention Court Order.
- 6.1.1. Collector and Local roads shall have a minimum right-of-way width of sixty (60) feet and Arterial roads shall have a minimum right-of-way width of one hundred (100) feet and must provide unhampered circulation through the subdivision. Alleys shall not be less than 20 feet in width. All trees, bushes and shrubs shall be removed from said right-of-way and no trees, bushes, or shrubs shall be allowed to grow in said right-of-way. A permanent dead-end street shall have a turn-around having an outside right-of-way diameter of 150 feet. Proposed right-of-way shall be inspected by the County Engineer prior to the beginning of construction.
- 6.1.2. All streets should intersect at 90-degree angles. Where this is not possible, any intersection angle of less than 80 degrees shall have a cord (corner cut) as specified by the Commissioners' Court, but in no case shall the cord be less than 25 feet.
- 6.1.3. All street and road grades must be approved by the Commissioners' Court before they are constructed. Two sets of Road and Drainage construction plans signed and sealed by a Professional Engineer shall be submitted to the County Engineer before the Preliminary Plat approval is given by Commissioners' Court. Final Plat approval does not indicate acceptance of roads for county maintenance.
- 6.2.** No street or road shall have an abrupt offset or “jog” in it. Developers are encouraged to avoid 90-degree turns and use gentle curves in so far as possible. Inside curves will be designed so that traffic will not be induced to use the ditch as part of the traveled way.
- 6.3.** Where part of a street has been dedicated in an adjoining subdivision adjacent to and along the common property line of the two subdivisions, enough width of right-of-way must be dedicated in the same subdivision to provide the minimum width specified herein.

- 6.4.** The County will not assume any liability or responsibility for the maintenance, repair or replacement of any structure used to impound water or any road over, around or next to any structure used to impound water.
- 6.5.** Remove and dispose of all trees, brush, rocks and other materials created by construction of road, street, and alley right-of-way.
- 6.6.** Subdivision entrances entering off a county road or state highway shall meet the approval of the Commissioners' Court and/or the Texas Department of Transportation prior to approval of the final plat.
- 6.7.** Sub-grade shall be watered, rolled and bladed to a depth of six inches before any base material is placed on it. Compaction equipment will be used to maximum advantage.
- 6.8.** The owner or his representative shall furnish the County with reports of analysis of the proposed material made by an approved laboratory. The owner or his representative shall furnish evidence of conformity with these specifications whenever called upon to do so by the County. Specifications for base material shall be in accordance with the most current Texas Department Of Transportation (TxDOT) Standard Specifications, Item 247. Flexible Base.
- 6.9.** Where a street or road section is constructed without curbs, the flexible base shall have a minimum thickness of 8" after compaction of a material approved by the County Engineer, and a minimum of 30 feet wide as shown on the Bandera County Road and Street Section.
- 6.10.** Where a street section (with curbs) is employed the base shall be a minimum of eight inches thick after compaction, and a minimum curb width of 30 feet face-to-face. All curbs shall be constructed in accordance with current specifications of the Bandera County Road Standards. The next increment of width shall be 10 feet, or a total curb width of 40 feet face-to-face, with a minimum thickness of base of eight inches. Alleys shall be 20 feet wide and eight inches in thickness after compaction. The finished centerline grade of alleys shall be lower than the abutting property to provide drainage.

**6.11.** All roads shall be paved with a two course surface treatment or Hot Mix Asphalt Concrete Pavement.

**6.12. See Appendix B ROAD STANDARDS**

6.19.1 More details and specifications about road and drainage standards are printed in the Appendix of these Rules.



## ARTICLE SEVEN: UTILITIES

### 7.1. Construction Guidelines

- 7.1.1. All conduits, water, gas, or otherwise, as well as telephone lines and electric cables, must be buried with the top of the pipe not less than 24" below the level of the ground, or below ditch level when crossing streets or roads. Underground lines will be prominently marked with warning signs along the length of the line.
- 7.1.2. All utility lines must be in the rear of homes or other buildings receiving service, or not in excess of three feet from the front lines adjacent to streets or roads as approved by the Commissioners' Court.
- 7.1.3 Utility poles shall be placed no more than two feet from the front lot lines adjacent to streets, unless otherwise authorized by the Commissioners' Court in writing.

### 7.2. Easements and Liability

- 7.2.1. The County will not assume any liability for damage to utility lines when maintaining roads.
- 7.2.2 Perpetual easements are reserved along and within 10 feet of the rear line, front line and side lines of all Lots for the installation and maintenance of poles, wires, downguys, and fixtures for electric lines and telephone lines, and to trim any trees that may interfere with the maintenance of such lines, with the right of ingress and egress from and across said premises to employees of utilities owning said lines; said easements to also extend along any owner's side and rear property lines in case of fractional tracts. It is understood and agreed that it shall not be considered a violation of the provisions of this easement if wires or cables carried by such pole lines pass over some portion of said tracts not within the twenty (20) foot wide strip as long as such lines do not prevent the constructions of buildings on any tracts in the development.

**ARTICLE EIGHT: MINIMUM LOT SIZES AND LOT GEOMETRY;  
GENERAL AND MISC. REQUIREMENTS**

The County has established certain minimum standards for Lot size and street frontage. These minimum acreage requirements do not apply to the combining of two or more lots that are part of an existing platted subdivision that has been approved by Commissioners Court and recorded with the county clerk.

**8.1.**

- 8.1.1. A Subdivision Lot served by an individual water supply well and an individual on-site sewage system (OSSF) shall have a minimum Lot size of ten acres.
  - a) These Lots shall have a minimum road/street frontage of 200 feet unless that frontage is on a cul-de-sac or cul-de-sac corner, in which case see paragraph 8.1.4.
  - b) So as to provide adequate spacing for a home or commercial building site, water well and an OSSF, the minimum Lots size must be maintained exclusive of any floodway that may encroach on the Lot.
- 8.1.2. Lots served by a public water supply and having an individual on-site sewage facility (OSSF) shall have a minimum Lot size of five acres.
  - a) These Lots shall have a minimum main lot street frontage of 150 feet unless that frontage is on a cul-de-sac or cul-de-sac corner, in which case see paragraph 8.1.4.
  - b) So as to provide adequate spacing for a home or commercial building site, the OSSF, the minimum Lot size must be maintained exclusive of any floodway that may encroach on the Lot.
- 8.1.3. Lots served by a public water supply and by a public sewage disposal system shall have a minimum Lot size of one half acre.
  - a) These lots shall have a minimum main lot access road/street frontage of 100 feet unless that frontage is on a cul-de-sac or cul-de-sac corner, in which case see paragraph 8.1.4.
  - b) The minimum Lot size must be maintained exclusive of any floodway that may encroach on the Lot.
- 8.1.4. The minimum road/street frontage of any lot on the turn around of a cul-de-sac or cul-de-sac corner shall be 50 feet chord length.

8.1.5 All lots shall comply with the applicable size restrictions in 8.1.1, 8.1.2, 8.1.3 and/or 8.1.4 stated above, with the exception of the following. In the event a Subdivision would result in a lot of a size less than that required under 8.1.1, 8.1.2, 8.1.3 and/or 8.1.4, (hereafter “Under-sized lot”) such Under-sized lot must be used exclusively for commercial purposes, and such Subdivision shall be subjected to consideration for approval by the Commissioners’ Court on a case by case basis. Any such Subdivision and Under-sized lot must be shown to comply with all other Bandera County platting rules and subdivision regulations, as well as all applicable laws, rules and regulations required by any other regulatory agencies which provide or may provide oversight over the proposed Subdivision. In the event the Commissioners’ Court approves such Subdivision under this Section 8.1.5., a statement in recordable form, signed by the Bandera County Engineer shall be recorded with the appropriate County records, which statement gives notice to the public that the approval of the Subdivision was contingent upon the restriction that the Under-sized lot shall be used exclusively for commercial purposes and that this restriction shall be in the nature of a covenant running with the land, and all future assignments, conveyances and/or transfers of the Under-sized lot or any part of the Under-sized lot, whether by itself or as part of another portion of property, shall be subject to such commercial use only restriction. An example of the Notice is attached hereto as Appendix M. In addition, the plat of a Subdivision that contains an Under-sized lot shall contain a statement (restriction) on its face that such Under-sized lot is subject to a commercial use only restriction as defined in Article 8.1.5 of the Bandera County Subdivision Land Development Rules and Regulations.

Any approved Under-sized lot and any and all structures located thereon shall be used exclusively for commercial purposes and activities, and in no event shall the Under-sized Lot and/or any Structure on an Under-sized Lot be used for residential purposes as defined herein.

As used herein “residential purposes” is to be given the broadest definition possible and includes without limitation the act by one or more persons of lodging, sleeping, living, abiding or dwelling for a single night or more, inside or outside of a Structure of any type located on the Under-sized lot, regardless of whether there is or is not a charge for such lodging, sleeping, living, abiding or dwelling.

A “building” is any Structure with four walls and a roof regardless of whether it is or is not permanently affixed to the Under-sized lot.

“Structure” includes but is not limited to the whole or any part of: a building, anything existing on the Under-sized lot that does not have four walls and a roof, a temporary Structure, a permanent Structure, a trailer of any kind, a mobile home, a modular home and/or a tent. The phrase “a trailer of any kind, a mobile home, a modular home and/or a tent” provides examples of what is intended to be included in the definition of “Structure” and is not intended to exclude any other type of structure that would otherwise fall within the given definition

For further clarification, transient lodging, the occupancy, lease or rental of any Structure on an Under-sized lot for residential purposes, as defined herein, and/or the use of an Under-sized lot and any Structure located thereon for an apartment, a tourist court, a trailer park, an inn, a lodging house, a rooming house, a bed and breakfast, a motel and/or a hotel is deemed a residential use or purpose. Such use of an Under-sized lot and any Structure located thereon is not allowed but specifically prohibited. A violation of this prohibition shall be subject to enforcement as provided in these Subdivision Rules and Regulations.

- 8.1.6. The developer shall place the following statement on the subdivision plat and in the subdivision restrictions if any: "Residential structures, to include mobile homes, built or placed on a lot which is lower than the elevation of any street/road abutting the lot shall be built/placed at an elevation high enough to prevent damage from drainage flow from or across the road.

**8.2. Flag Lots Generally Not Permitted**

8.2.1. See definition at Article Two.

8.2.2 Flag lots shall generally not be permitted, except 1) where 60 feet of lot frontage on public ROW or 2) with public access where flag pole is not less than 60 feet in width or 3) if approved by Commissioners Court as consistent with the intent and spirit of these regulations. All flag lots must meet minimum acreage requirements in accordance with Section 8.1 excluding "flag pole".

**8.3. Cattle Guards**

8.3.1. All cattle guards in subdivisions must be 8' wide by 16' in length as a minimum and supported with a minimum of eight (8) I-beams 4" wide and 12" deep with a web and flange of 3/8" thickness or more. See Cattle Guard detail, Appendix B-22.

**8.4. Subject to Change**

8.4.1. These rules, regulations and requirements are subject to change, amendment or alteration without notice, whenever the Court in its judgment deems it to be in the best interest of the public.

**8.5. Tax Certificates Required**

8.5.1. Certificates from all taxing authorities with jurisdiction over any part of the property

**8.6. Deed Restrictions**

8.6.1. Bandera County shall not enforce deed restrictions, although as allowed by law the County may enforce plat notes which might be similar in content to deed restrictions.

**8.7. Discharge of Firearms on Small Lots**

8.7.1. Commissioners' Court of Bandera County encourages all Applicants to place in their subdivision restrictions that the discharging of firearms within a Subdivision be prohibited.

8.7.2. To promote the public safety, the Commissioners' Court by order has adopted Article 235.022, Subchapter Chap. B, Local Gov't Code, "Regulating the discharge of firearms on lots that are 10 acres or smaller and are located in the unincorporated area of the County in a subdivision."

**8.8. Hunting With Bows And Arrows**

8.8.1. Commissioners' Court of Bandera County encourages all Applicants to place in their subdivision restrictions that hunting with bows and arrows within a Subdivision be prohibited.

8.8.2. To promote the public safety, the Commissioners' Court by order has adopted Article 235.042, Subchapter C of the Local Government Code to prohibit hunting with bows and arrows on Lots that are 10 acres or smaller and are located in the unincorporated area of the County in a subdivision.

## ARTICLE NINE: REVISION OF SUBDIVISION PLAT

### 9.1. Application

A person who has subdivided land that is subject to the subdivision controls of the county in which it is located may apply in writing to the Commissioners' Court of the county for permission to revise the subdivision plat that has been filed for record with the County Clerk.

### 9.2. Notice

After the application is filed with the Commissioners' Court, the Court shall cause a notice of the application to be printed in a newspaper of general circulation in the County. The notice must include a statement of the time and place at which the Commissioners' Court will meet to consider the application and to hear protests to the revision of the subdivision plat.

### 9.3. Grant of Permission

The Commissioners' Court, during a regular term of the Court, shall adopt an order permitting the person to revise the subdivision plat if it is shown to the Court:

- a) That the revision will not interfere with the established rights of any owner of a part of the subdivided land; or
- b) If the revision may interfere with the rights of an owner of a part of the subdivided land, that the owner has agreed to the revision.
- c) That the plat revision of one or more lots that currently meet the requirements of the Subdivision and Land Development Rules and Regulations ("Rules") will result in creating lots that maintain compliance with the "Rules" in every respect.  
**Adopted By Commissioners' Court April 27, 2006.**
- d) That the plat revision combines two or more lots that do not meet the current "Rules" to create lots that are larger than the original or parent lot or lots that meet the "Rules". The resulting lots shall meet current On Site Sewage Facilities regulations and comply with Bandera County River Authority and Groundwater District rules for water well permitting.

**Adopted By Commissioners' Court April 27, 2006.**

**9.4. Recording Requirement**

9.4.1. If the Commissioners’ Court permits a person to revise a subdivision plat, the person may make the revision by filing for record with the County Clerk a revised plat or part of a plat showing the changes made to the original plat.

9.4.2. Plat revision will be presented to the Commissioners’ Court in the same manner as the original was submitted.

9.4.3. Filing and recording fees:

Plats less than 33 lots .....	\$100.00
Plats over 33 lots .....	\$100.00 plus \$3.00 per additional lot over 33 lots
Records Management .....	\$ 5.00 per plat
Archives Fee .....	\$ 5.00 per plat
Courthouse Security Fee .....	\$ 1.00 per filing

## **ARTICLE TEN: CONSTRUCTION BOND**

- 10.1.** In order to insure that the streets and alleys in accepted and approved Subdivisions are constructed in accordance with these Rules, the Applicant shall file a construction bond or an alternative financial guarantee. The Construction Bond shall be executed by some surety company authorized to do business in this state, payable to the County Judge of Bandera County, Texas, or to his successors in office. Construction Bond shall be based on the estimated cost of site improvements, to include streets, alleys, storm drainage and all incidentals associated with the work. The bond shall include the construction start time and the expiration date. The County Engineer shall review and approve Engineers cost estimate for bond and construction plans.
- 10.2.** Construction must start within 90 days of Final Plat approval and all construction shall be completed and approved within 12 months of Final Plat approval.
- 10.3.** Financial Guarantee may also be in the form of a surety bond, cash bond or an irrevocable letter of credit issued by a federally insured financial institution and approved by Commissioners' Court.

## ARTICLE ELEVEN: VARIANCES

- 11.1. Criteria for Variance.** The Commissioners' Court shall have the authority to grant variances from these Rules, and from any specifications and regulations included in the Appendix, or from other subdivision and development related specifications, when the public interest or the requirements of justice demands relaxation of the strict requirements of the Rules. Factors to be considered by the Court in evaluating a request for variance shall include:
- 11.1.1. The actual situation of the property in question in relation to neighboring or similar properties, such that no special privilege not enjoyed by other similarly situated properties may be granted;
  - 11.1.2. Whether strict enforcement of the Rules would deny the Applicant the privileges or safety of similarly situated property with similarly timed development;
  - 11.1.3. That the granting of the variance will not be detrimental to the public health, safety and welfare, or injurious to other property or will not prevent the orderly Subdivision of the land in the area in accordance with these Rules; and,
  - 11.1.4. Whether there are special circumstances affecting the land or proposed Subdivision (or other development) such that strict application of these Rules would deprive the applicant the reasonable use of the land, and that failure to approve the variance would result in undue hardship to the Applicant. Financial hardship, standing alone, shall not be deemed to constitute undue hardship.
- 11.2. Application Materials.** Any person who wishes to receive a variance shall submit with an Application for Preliminary Plan a written request for variance, including a description of, and a written justification for, each variance requested.
- 11.3. Discretion to Grant Variances.** The decision of the Commissioners' Court whether to grant or deny a variance is at its complete discretion, and will be final.
- 11.3. Variances as Matter of Record.** A motion to approve a variance may be approved by a simple majority of the Commissioners' Court. A motion to approve a variance should include a statement, orally or in writing, to be included in the Minutes of the Court, summarizing the reasons for granting the variance.



## ARTICLE TWELVE: ENFORCEMENT AND PENALTIES

**12.1. Category of Offense.** A person commits an offense if the person knowingly or intentionally violates a requirement of these Rules, including the Road and Drainage Specifications incorporated into the Appendix B, the Regulations of Bandera County for On-Site Sewage Facilities, or the Manufactured Home Rental Community regulations included in Appendix A. An offense under this provision is a Class B misdemeanor punishable by fine or imprisonment or both.

**12.2. Enforcement Actions.** At the request of the Commissioners' Court, the County Attorney or other prosecuting attorney for the County, may file an action in a court of competent jurisdiction to:

12.2.1. Enjoin the violation or threatened violation of a requirement established by or adopted by the Commissioners' Court under these Regulations; or

12.2.2. Recover damages in an amount adequate for the County to undertake any construction or other activity necessary to bring about compliance with a requirement established by or adopted by the Commissioners' Court under these Rules.

**12.3. Enforcement of Plat Notes.**

The enforcement of plat notes or restrictions is generally the responsibility of the Applicant and other persons holding a property interest, whether in fee simple or by easement, in the Subdivision. Plat notes shall reflect that the County may enforce any plat notes imposed pursuant to the regulations of Bandera County for On-Site Sewage Facilities or these Rules, any plat note affecting County rights of way or drainage or the public health, safety and welfare. Moreover, the Commissioners' Court shall have the right and authority through appropriate legal procedures to prohibit the construction or connection of utilities or issuing of permits if the plat notes or restrictions have been violated.

**ARTICLE THIRTEEN**

**- RESERVED -**

## **ARTICLE FOURTEEN: SEVERABILITY**

In the event any section, appendix, paragraph, sentence, clause or phrase of these Regulations shall be declared unconstitutional or invalid by the valid judgment or decree of any court of competent jurisdiction, such unconstitutionality or invalidity shall not affect any remaining phrases, clauses, sentences, paragraphs, sections, or appendices of these Regulations. It is the express intent of the Bandera County Commissioners' Court that the sections, appendices, paragraphs, sentences, clauses or phrases of these Rules be severable.

# INDEX

Addressing .....	18
Alleys .....	35
Application.....	7
aquifer .....	7
Aquifer .....	7, 23
Aquifer testing .....	24
Bandera Electric Cooperative .....	14, 18
BCRAGD .....	21
Cattle Guards .....	39
certificate of dedication.....	18
Certification of Groundwater Availability.....	7
Certification of Groundwater Availability for Platting .....	20
citations .....	2
Commissioners’ Court .....	1, 3
Conductivity and pH values.....	29
construction bond.....	43
corner cut .....	34
dead-end street .....	34
Deed Restrictions .....	39
Designated Agent.....	7
Determination of Groundwater Availability .....	30
Determination of Groundwater Quality .....	29
developed in phases .....	19
Drinking water standards .....	7
Easements .....	37
electric lines and telephone lines .....	37
elevation.....	17
elevation in flood prone area.....	17
Enactment .....	6
Enforcement.....	45
Enforcement of Plat Notes .....	45
Engineers cost estimate.....	43
Filing and recording fees .....	19
Final Plat .....	8, 16
firearms .....	39
Flag Lot.....	8
Flag Lots.....	39
Flood Insurance Rate Map (FIRM) .....	14
Flood Damage Prevention Court Order .....	34
geophysical logs.....	25
Hot Mix Asphalt Concrete. ....	36
inspection fee .....	19
lien holders. ....	15
Lot size.....	38
observation well.....	24
original survey .....	16
Perpetual easements.....	37
Plat revision .....	42
Preliminary Plan.....	13
Public Water System.....	9
Regulations .....	3
revised plat .....	42
Road Standards .....	9
scale.....	13
septic tanks.....	33
Site-Specific Groundwater Data .....	23
Sketch Plan.....	9, 11
street frontage.....	38
Street name.....	17
TAC.....	10
TCEQ .....	10
Test well.....	24
Title 30 Texas Administrative Code (30 TAC) ....	21
utilities.....	37
variances .....	44
violation .....	45
U. S. Geological Survey.....	16
wastewater.....	33
WATER AVAILABILITY .....	20
Water Demand Estimate .....	22
Water quality analysis.....	29
Water-level recovery data .....	27
well development.....	25
Well interference.....	31

**APPENDIX A**

**SURVEY AND INFRASTRUCTURE REQUIREMENTS FOR MANUFACTURED  
HOME RENTAL COMMUNITIES**

## APPENDIX A

### Bandera County, Texas

### **SURVEY AND INFRASTRUCTURE REQUIREMENTS FOR MANUFACTURED HOME RENTAL COMMUNITIES**

#### **Preamble:**

**Whereas**, the 76<sup>th</sup> State Legislature of the State of Texas has enacted legislation amending Section 232.007, Texas Local Government Code, Subsection (a) and adding Subsections (c) through (h) enabling Commissioners' Courts to adopt infrastructure requirements for Manufactured Home Rental Communities; and:

**Whereas**, due notice was given of a meeting and public hearing to determine whether the Commissioners' Court of Bandera County, Texas should enact an order establishing infrastructure requirements for Manufactured Home Rental Communities; and

**Whereas**, the Commissioners' Court of Bandera County, Texas finds that the requirements enumerated below will help to insure the safe ingress and egress of emergency vehicles, protect against loss of life and property in the event of flooding or other emergencies, and insure adequate water and wastewater facilities for the citizens of Bandera County; and

**Whereas**, the Commissioners' Court of Bandera County, Texas has considered the matter and deems it appropriate to enact this Order adopting minimum infrastructure requirements for Manufactured Home Rental Communities, and to incorporate this Order and these regulations into its Subdivision and Development Rules,

**Now, therefore, be it resolved and ordered on this 21<sup>st</sup> day of April, 2005**, that the Commissioners' Court of Bandera County, Texas adopts the following minimum infrastructure requirements for Manufactured Home Rental Communities:

#### **Order of the Commissioners' Court:**

#### **SECTION 1 - DEFINITION OF AFFECTED DEVELOPMENTS**

- 1.1** As used in this Order, the term "Manufactured Home Rental Community," abbreviated as MHRC, means any plot or tract of land that is separated into two or more spaces that are rented, leased, or offered for rent or lease, for a term of less than 60 months without a purchase option, for the installation of manufactured homes for use and occupancy as residences. "Manufactured Home" means any manufactured home or mobile home manufactured to the code or specifications of the federal Department of Housing and Urban Development, and/or any residence as defined by Section 3 of the Texas Manufactured Housing Standards Act (Article 5221, Texas Civil Statutes); used collectively, the term "Manufactured Home" refers to both manufactured homes and mobile homes.

- 1.2 **Definitions:** Streets and roads- A public road, a private drive, or any other avenue of ingress or regress intended to provide access to all or any part of the MHRC consisting of more than one space.

## **SECTION 2 - CONSTRUCTION START**

- 2.1 Construction of a proposed MHRC may not begin before an Infrastructure Development Plan, if required, has been approved by the Commissioners' Court, or by a county official or employee designated by resolution to act as an agent of the Court.

## **SECTION 3 - UTILITY HOOK-UPS**

- 3.1 A utility may not provide utility services, including water, sewer, gas, or electric services to an MHRC until a Final Survey and an Infrastructure Development Plan have been approved by the Commissioners' Court.

## **SECTION 4 - FINAL SURVEY AND INFRASTRUCTURE DEVELOPMENT PLANS REQUIRED**

- 4.1 The Applicant for a tract of land intended to be used as a MHRC shall have prepared and submitted to the County a Final Survey and an Infrastructure Development Plan (IDP). In the rare event that there will be no infrastructure in the proposed MHRC, then only a Final Survey will be required. The owner shall submit 10 blueline or blackline copies and two reproducible prints of the Final Survey, and shall submit 10 blueline or blackline copies and two reproducible prints of the IDP and 10 copies of supporting materials. All original materials should have original seals and signatures of the Texas Registered Professional Land Surveyor and Texas Registered Professional Engineer who prepared them. An electronic file of the Final Plat in a format acceptable to the County Engineer will also be submitted. The Final Survey and the IDP shall show or be accompanied by the following information:

- 4.1.1 **DRAWING REQUIREMENTS:** The north arrow, graphic scale and date shall be shown. The Final Survey and IDP shall be drawn on 24"x36" sheets to a scale not exceeding one inch equals two hundred feet (1"=200'). The recording Final Survey and IDP shall be on permanent type material equivalent or superior to mylar. If the recording Final Survey and IDP is a photographic reproduction of a larger scale original, the reduction shall be no more than 50%. All figures and letters shown must be plain, distinct, and of sufficient size as to be easily read, no smaller than 0.09 inches in height, and must be of sufficient density to make a lasting and permanent record. A vicinity map shall be included that shows the location of MHRC's in relation to major roads, towns, cities or topographic features. All county, city, school district, or special taxing districts that fall on or adjacent to the MHRC must be shown on the Final Survey and the IDP.
- 4.1.2 **MANUFACTURED HOME COMMUNITY DETAILS:** The name of the MHRC, graphic scale, north arrow, names of streets, and block and space boundaries and block and space numbers within the MHRC shall be shown. Adjacent property owners,

subdivisions, and MHRCs shall also be shown and identified by owner's name and deed or plat reference.

- 4.1.3 OWNER IDENTIFICATION: The name, addresses, and telephone numbers of the owner or owners of a proposed MHRC, and the name, address and phone numbers of the surveyor or engineer responsible for the preparation of the Final Survey and IDP shall be shown. If the owner is a corporation, partnership or joint venture, the names and address of the corporate officers, partners or joint venturers shall be provided. The name, address and phone numbers of any lien holders will also be shown on the MHRC and IDP.
- 4.1.4 BOUNDARY LINES: The perimeter boundary of the community and each boundary or space shall be shown with bearings and distances, referenced to a corner of the Final Survey, IDP and in relation to original survey boundaries. The bearings and distances shall be shown with distances accurate to one-hundredth of a foot and bearings accurate to one-hundredth of a second of a degree. Curves shall be shown with curve length, radii, and chord bearing and distance. Any and all other information necessary to duplicate the Final Survey and IDP on the ground is required. The square footage or acreage to the nearest one-hundredth of each space must be shown in each Final Survey and IDP. A table of space square footage or acreage, the total square footage or acreage, and the total number of spaces must be shown. Bandera County Road Standards are located in Appendix B.
- 4.1.5 UTILITY SERVICE: Each utility service shall approve the Final Survey and IDP in writing and provide the County with a letter certifying its approval and its ability to provide service to the MHRC.
- 4.1.6 LAYOUT OF SPACES, EASEMENTS, SETBACK LINES: Location of lots, spaces, streets, roads, public highways, utility easements, parks, benchmarks, 100-year flood plain boundaries and other pertinent features, shall be shown by bearing and distance. The bearings and distances shall be shown with distances accurate to one-hundredth of a foot and bearings accurate to one-hundredth of a second of a degree. Curves shall be shown with curve length, radii, central angle and chord bearing and distance. Any and all other information necessary to duplicate the Final Survey and IDP on the ground is required. The location of drainage easements and other public rights of way or future rights of way shall be shown. The names and locations of all drives and roads shall be clearly shown, and shall be coordinated with the County's 911 Coordinator and to avoid confusion or duplication in street or drive names. A letter from the County's 911 Addressing Coordinator shall be provided to the Commissioners' Court certifying street and drive name approval. One 911 address will be provided to the rental community; unit numbers are required to be assigned to and clearly marked for each rental space as shown on the Final Survey and IDP.
- 4.1.7 ON-SITE SEWAGE: If utilizing individual on-site sewage facilities, each Lot must meet the requirements of the Bandera County Rules for On-Site Sewage Facilities. Lot



- numbers and block designations shall be shown on the IDP. Each Lot shall have a minimum of 50 feet of road frontage.
- 4.1.8 CERTIFICATION AND DEDICATION OF OWNER: The Applicant shall certify the dedication for public use forever all streets, alleys, utility and drainage easements, parks, and any other land dedicated for public use, on the first page of the IDP with signature and acknowledgment before a notary public.
- 4.1.9 CERTIFICATION BY REGISTERED PROFESSIONAL LAND SURVEYOR: The Texas Registered Professional Land Surveyor shall certify on the first page of the Final Survey and IDP that the survey correctly represents a survey made on the ground under his supervision, and the dimensions, bearings, acreage and other technical information shown on the Final Survey and IDP are precise and accurate. Final Surveys and IDPs shall not be approved until all benchmarks are placed and placement is certified by the Surveyor.
- 4.1.10 CERTIFICATION AND APPROVAL BY CITY: Certification of approval signed by the appropriate representatives of any city having extraterritorial jurisdiction over the area in which the MHRC is located shall be placed on the first page of the IDP. All information required by the city for approval, i.e. plans and specifications, shall also be submitted to the County along with the IDP.
- 4.1.11 RESTRICTIONS OF COMMUNITY: A copy of the Covenants, Conditions and Restrictions (CCRs), if any, within the MHRC shall accompany the IDP, and shall be notarized and filed for record in the office of the County Clerk.
- 4.1.12 STATUS OF AD VALOREM TAXES: Each owner or applicant shall provide tax certificate(s) demonstrating there are no delinquent taxes due or owed for any and all tracts containing the MHRC as furnished through the Bandera County Tax Assessor/Collector's Office.
- 4.1.13 STREET STANDARDS: Streets shall be arranged and constructed so as to provide each manufactured home with direct access to an all-weather roadway suitable for two-way traffic. Street drainage, width, subgrade, base and driving surface shall be designed using good engineering practices consistent with the express purpose of, at a minimum, assuring speedy emergency access to each home or manufactured home in the community. "Flag Lots" or other contrivances which unduly inhibit proper road maintenance or result in lengthy private drives that are likely to restrict the practicable ingress and egress of emergency vehicles in all types of weather are prohibited. Drive plans, section profiles, and a prospective maintenance plan and schedule for all drives shall be attached as part of the IDP. One source of appropriate road specifications is the Road and Drainage Standards contained as part of the Bandera County Subdivision and Development Rules, including this Appendix B.

- 4.1.14 **DRAINAGE STANDARDS:** In order to protect property and life, as provided for in Chapters 232.007 and 240.905 of the Texas Local Government Code, the IDP shall include a drainage plan, flood plain delineation, and floodway delineation, prepared in accordance with good engineering practices, identifying areas included in the 100-year flood plain as well as the proposed finished floor elevations of any manufactured homes to be placed in proximity to the flood plain. Finished floor elevations must be at least one foot above base flood elevation. In addition, the IDP must include a reasonable plan based on good engineering practices signed and sealed by a Texas Registered Professional Engineer to provide for adequate drainage for the MHRC without increasing the peak flow under post-development conditions for a 100-year storm event. In all MHRCs containing or adjacent to 100-year floodplain; benchmarks must be placed showing the elevation from Mean Sea Level as well as true latitude and longitude.
- 4.1.15 **IMPROVEMENTS STATEMENT:** Each IDP shall have the following note on the first page. “The paving, grading easements and/ or drainage improvements associated with this IDP do not constitute acceptance of same for maintenance purposes by Bandera County.” When IDP or drainage plans are provided, the engineer shall certify by signing and sealing on the first page of the IDP the following statement: “I, \_\_\_\_\_, a Texas Licensed Professional Engineer, do hereby affirm to the best of my knowledge information and belief and based upon the information provided, that the drainage improvements shown on this Infrastructure Development Plan are in accordance with good engineering practices, laws, and regulations and will not increase runoff above undeveloped conditions. I further declare that I will accept full responsibility for the integrity of the drainage design and will defend and hold harmless Bandera County from any claim or litigation arising from any errors, omissions, or other acts of negligence in the preparation of same.”

#### **SECTION 5 - FINAL SURVEY AND IDP APPROVAL**

The Commissioners’ Court of Bandera County shall approve or reject the Final Survey and/or IDP within 60 business days of its being submitted. Failure to reject the plan within the time prescribed shall constitute the County’s acceptance of the plan as required by Section 232.007 of the Texas Local Government Code.

#### **SECTION 6 - INSPECTION AND CONFIRMATION OF CONSTRUCTION**

The Commissioners’ Court of Bandera County shall approve or reject the IDP prior to the commencement of construction of any street, drainage or utility improvements. The Applicant, or the Applicant’s authorized agent, shall arrange a preconstruction meeting with the County Engineer to discuss the timing and nature of inspections by the County during all phases of construction. The County may designate a private engineer, road contractor, testing company or other entity to serve as its agent for inspections. In any event, the Applicant shall be required to pay for any reasonable testing requested by the County or Designated Agent. The final inspection shall occur no later than the second business day after the owner delivers written confirmation that all improvements have been completed to the standards established in the IDP as required by Section 232.007 of the Texas Local Government Code.

If the County determines that the infrastructure complies with the IDP, the County shall issue a certificate of compliance no later than the fifth business day after the date of the final inspection; or, where no inspection is required, no later than the fifth business day after the receipt of the owner's letter of completion. If the County determines that the infrastructure does not comply with the IDP, the MHRC may not be occupied until those deficiencies identified by the County are remedied to the satisfaction of the Commissioners' Court.

**SECTION 7 – REVIEW FEES**

The County Clerk shall collect a fee of \$250 plus \$10 per rental space at the time the application is filed.

**SECTION 8 - SEVERABILITY**

The various points and conditions enumerated in this Order are intended to stand alone as well as part of the larger Order, and, therefore, should any part of this Order be repealed by the Commissioners' Court or struck down by a court of law, the remaining parts, points, numbers and conditions of this Order shall remain in effect until expressly repealed or amended by the Commissioners' Court of Bandera County.

## **APPENDIX B**

### **ROAD STANDARDS**

**ROAD STANDARDS**

**BANDERA COUNTY  
TEXAS**

RICHARD A. EVANS  
JAMES MORMANDO, JR.  
RONALD D. BASINGER  
RALPH CHANCY  
NANCY J. THOMPSON

COUNTY JUDGE  
COMMISSIONER, PREC. 1  
COMMISSIONER, PREC. 2  
COMMISSIONER, PREC. 3  
COMMISSIONER, PREC. 4

PREPARED BY

RAYMUNDO RENDON, JR., P.E.  
COUNTY ENGINEER

ADOPTED  
BY  
COMMISSIONERS' COURT  
DECEMBER 28, 2000

## **Bandera County, Texas - ROAD STANDARDS**

### **A. MINIMUM SUBDIVISION ROAD AND DRAINAGE STANDARDS**

- i. Pursuant to the Texas Local Government Code, and various other statutes and regulations cited in the Preamble to these Rules, Bandera County has the authority to adopt and enforce road construction standards.
- ii. Such authority gives Bandera County the power to adopt reasonable Standards for the construction of roads and streets and for the necessary drainage within subdivisions.
- iii. The County Commissioners' Court, pursuant to the Local Government Code, may refuse to approve or authorize the filing of any subdivision map or plat that does not meet the County standards for construction of roads and streets and for the necessary drainage within subdivisions.
- iv. The Bandera County Commissioners' Court adopts the attached ROAD STANDARDS thereby establishing minimum standards for the construction of roads and necessary drainage within subdivisions. Said standards to replace any existing regulations regarding subdivision road standards.
- v. Said ROAD STANDARDS shall become part of and incorporated by reference and a part of the County's subdivision regulations.

### **B. BANDERA COUNTY ROAD STANDARDS**

- i. Pursuant to the Texas Transportation Code Bandera County has the authority to make and enforce all necessary rules and orders for the construction of public roads.
- ii. Pursuant to the Texas Local Government Code Bandera County has the authority to adopt reasonable specifications for the construction of roads, streets and drainage features and structures within subdivisions.
- iii. The Bandera County Commissioners' Court adopts the Bandera County Road Standards dated December 28, 2000 thereby establishing all necessary rules and orders for the construction of public roads, streets, and drainage features and structures within subdivisions. Said standards to replace any existing Bandera County Road Standards.
- iv. Bandera County Road Standards shall become part of and be incorporated by reference into Regulations Governing Subdivisions in Bandera County.

**TABLE OF CONTENTS**  
**ROAD STANDARDS**  
**BANDERA COUNTY**

<b>DEFINITIONS</b>	B - 5
<b>ROAD DESIGN AND CONSTRUCTION</b>	B - 7
1.0 Construction Requirements	B - 7
2.0 Plans	B - 7
3.0 Sight Distance	B - 8
4.0 Vertical Curvature	B - 8
5.0 Horizontal Curvature	B - 9
6.0 Grade	B - 9
7.0 Cross Section Standards	B - 9
8.0 Sub Grade Preparation	B - 10
9.0 Base or Base Courses	B - 10
10.0 Pavement	B - 10
11.0 Cattle Guards	B - 11
12.0 Cul-De-Sacs	B - 11
13.0 Right-of-Way	B - 11
14.0 Road Jogs	B - 11
15.0 Road Intersections	B - 11
16.0 Non-access Easement	B - 11
17.0 Utility Cuts	B - 11
18.0 Dams and Spillways	B - 11
19.0 Signs	B - 11
20.0 Mail Delivery Area	B - 12
<b>DETAILS – ROAD STANDARDS</b>	
1.0 Figure 1 – Arterial Road – 28 Foot Pavement Width	B - 13
2.0 Figure 2 – Collector Road – 24 Foot Pavement Width	B - 14
3.0 Figure 3 – Local Road – 22 Foot Pavement Width	B - 15
4.0 Figure 4 – Collector or Local Road – Curbed Section	B - 16

5.0 Figure 5 – Cul-De-Sac Typical Detail	B - 17
6.0 Figure 6 – Base and Pavement Replacement for Utility Cut	B - 18
7.0 Figure 7 – Headwalls for Culverts	B - 19
8.0 Figure 8 – Interceptor Drains for Intercepting Sheet Flow	B - 20
9.0 Figure 9 – Driveway and Culvert Detail	B - 21
10.0 Figure 10 – Cattle Guard	B - 22
<b>STORM DRAINAGE</b>	B - 23
1.0 Method of Computing Runoff	B - 23
2.0 Runoff Calculations	B - 23
3.0 Concrete Lined Channels	B - 24
4.0 Earth Channels	B - 25
5.0 Drainage Structures	B - 25
6.0 Roadway Ditches	B - 25
7.0 Driveway Culvert Pipe	B - 25



## DEFINITIONS

The following terms, phrases, words and their derivations shall have the meaning given in this section.

**Alley:** A minor public right-of-way, not intended to provide the primary means of access to abutting lots, which is used primarily for vehicular service access to the back or sides of properties otherwise abutting on a public road.

**ASASHTO:** American Association of State Highway and Transportation Officials.

**ASTM:** American Society for Testing of Materials.

**Building Setback Line:** The “building set back line” is minimum horizontal distance between a building and the adjacent right-of way road line.

**Concrete Monument:** Permanent concrete survey marker.

**Contour:** A contour is an imaginary line of constant elevation on the ground surface. The corresponding line on a map is called a contour line.

**County:** Bandera County, Texas

**Cul-de-sac:** A “cul-de-sac” is the vehicular turnaround at the end of a road.

**Driveway:** A portion of a lot used for access to the lot from a public road or street not used for public circulation.

**Engineer:** A person duly authorized and properly registered under the provisions of the Texas Registration Act, as heretofore or hereafter amended, to practice the profession of engineering.

**Improvements:** Roads, streets, curbs, drainage structures, water systems, sewage systems, etc., the construction that may be required by the County.

**Lot:** A “lot” is an undivided tract or parcel of land having frontage on a road, which is, or in the future may be, offered for sale, conveyance, transfer or improvement; which is designated as a distinct and separate tract; and is identified by a tract or lot number which has been properly filed for record.

**Pavement Width:** The portion of road available for vehicular traffic that is between opposite edges of the pavement.

**Plat:** A “plat” is a complete and exact subdivision plan submitted to the Commissioners’ Court for final approval and which, if approved, will be submitted to the County Clerk for recording.

**Road:** A right-of-way or easement, however designated, which provides vehicular access to adjacent land.

**Arterial Road:** An “arterial road” serves a large area. It is a heavily traveled route connecting urban areas, and major traffic generators.

**Collector Road:** A “collector road” is a principal thoroughfare within a subdivision. It collects traffic from local roads and channels the traffic into the arterial system.

**Local Road:** a “local road” is a low volume road that serves traffic generating points or terminal points. It provides direct access to the lots or residence and has relatively light traffic volumes.

**Regulations:** Bandera County Subdivision Rules and Regulations.

**Right-of-Way:** The area within the outermost boundaries of a road including the area for a constructed watercourse or drainage ditch.

**Shall, May:** The word “shall” is always mandatory. The word “may” is merely directory.

**Street:** Roads as used herein.

**TxDOT:** Wherever mentioned refers to the Texas Department of Transportation.

**TxDOT Current Specifications:** Refers to the Standard Specifications for Construction and Maintenance of Highways, Streets, and Bridges.

**Utility Easement:** “Utility easement” is an interest in land to the county for installing and maintaining utilities, across, over or under private land together with the right to enter thereon with machinery and other vehicles necessary for the maintenance of said utilities.

**Utility Lines:** An apparatus used to convey a utility to the consumer (i.e. Telephone or electric lines or buried cable, water lines, gas lines, etc.)

**Vehicular Non-access Easement:** A “vehicular non-access easement” is an easement established on a lot for the purpose of prohibiting ingress and egress to vehicular traffic.

## **ROAD DESIGN AND CONSTRUCTION**

### **1.0 Construction Requirements**

All public and private roads in subdivisions and all public roads that are outside of subdivisions or outside the extraterritorial jurisdiction of any municipality shall be constructed in accordance with these Standards.

The County Attorney or other prosecuting attorney representing the County shall file an action in a court of competent jurisdiction to:

- a. Enjoin the violation or threatened violation of a requirement established by or adopted by the Commissioners' Court under Chapter 232 of the V.T.C.A., Local Government Code; or
- b. Recover damages in an amount adequate for the County to under take any construction or other activity necessary to bring about compliance with a requirement established by the Commissioners' Court under Chapter 232 of the V.T.C.A., Local Government Code.

### **2.0 Plans**

The plans for road and drainage improvements shall include the following information:

- a. Typical sections showing the proposed pavement width, type, thickness, and Crown; the proposed parkway grading slopes; and construction details of all drainage improvements including dimensions and reinforcing.
- b. Alignment of each road and drainage improvement showing a beginning and ending station; each deflection angle of the center line and the station of the point of intersection; the station of the point of curvature and the point of tangency of each curve; the station and angle of the intersection of each intersection of roads; the station and radius of each curb return; length, width, and thickness of base.
- c. The centerline grade at each fifty-foot station; the gradient of each tangent- grade and the location and length of each vertical curve. The profiles of roads and drainage ditches shall show the natural ground at adjacent property lines and the proposed centerline.
- d. Scale, north arrow, date, and name of road. Plans and profiles shall be drawn to scales of one (1) inch equals fifty (50) feet horizontally and one (1) inch equals five (5) feet vertically. The County Engineer may approve different scales upon request.
- e. Plans and subdivision plats shall have contours. The contour interval shall be two (2) foot for grades up to five (5) percent and five (5) foot for grades over five (5) percent.
- f. All plan and profiles shall bear the seal of a Registered Professional Engineer.
- g. Two sets of construction plan and profiles shall be submitted for approval of all road and drainage improvements. Drainage calculations, a copy of subdivision plat, and cost estimate of improvements shall also be submitted with construction plans.

### 3.0 Sight Distance

The following minimum sight distances shall be provided for safe stopping and intersection operations:

**Table 1.  
Minimum Stopping Sight Distance**

<u>Street Classification</u>	<u>Sight Distance</u>
Arterial Road	300 feet
Collector Road	300 feet
Local Road	250 feet

### 4.0 Vertical Curvature

A gradual transition from one roadway grade to another shall be accomplished by means of a vertical parallel curve connecting two (2) intersecting tangents. The minimum length of vertical curve shall be computed from the following formula:

$$L = KA$$

L = the length of vertical curve in feet

K = a constant related to sight distance and geometry of a parabolic curve (see Table 2.)

A = the algebraic difference in grades in percent

**Table 2.  
Design Values for Constant "K"  
Vertical Curvature**

<u>Street Classification</u>	<u>Crest Curves</u>	<u>Sag Curves</u>
Arterial Road	70	60
Collector Road	55	55
Local Road	55	55

### 5.0 Horizontal Curvature

Horizontal curvature shall be provided by simple circular curves with a constant radius for the safety and comfort of motorists. The following minimum radii shall be used in designating horizontal curves. Table 3 designated by State Department of Highways and Public Transportation.

**Table 3.  
Horizontal Curvature**

<u>Street Classification</u>	<u>Minimum Center Line Radius "R"</u>
Arterial Road	700 feet
Collector Road	400 feet
Local Road	100 feet

**6.0 Grade**

Road grades shall conform to the terrain and shall not exceed the following:

**Table 4.  
Road Grades**

<u>Street Classification</u>	<u>Maximum Grade</u>
Arterial Road	6%
Collector Road	12%
Local Road	12%

No road grade shall be less than five-tenths of one percent (0.05) unless otherwise specified by the County Engineer.

**7.0 Cross Section Standards**

The subdivider shall develop roads in accordance with the minimum standards detailed in Figures 1 through 4.

The subdivider may choose to design a pavement structure in accordance with the American Association of State Highway and Transportation Officials (AASHTO) Guide for Design of Pavement Structure. The pavement design report shall be prepared and signed by a Professional Engineer registered in the State of Texas.

**8.0 Sub Grade Preparation**

- a. Clearing and Grubbing: The entire area of the sub grade shall be cleared and grubbed to a depth of not less than 6" below natural ground in fill areas and one foot below sub grade elevation in excavated areas. Brush and other debris shall be removed from the right-of-way and disposed of.
- b. Density: Sub grades shall be constructed and finished with a minimum density of 95% of a standard proctor for in place materials or proof rolled by equipment as approved by the County Engineer.
- c. High Plasticity Soils: High plasticity index soils shall be stabilized with lime or cement as approved by the County Engineer.

**9.0 Base or Base Courses**

a. Material: Material for base courses shall be in accordance with Texas Department of Transportation (TxDOT) Standard Specification as specified for each of the following type of roadway. Pit-run base material and Caliche will not be an approved material for base courses.

Arterial Road	Type A, Grade 2
Collector Road	Type A, Grade 2
Local Road	Type A, Grade 2

b. Construction Methods: Base on all roads shall have a compacted depth of not less than eight (8”) inches and shall be constructed in two equal courses. The material shall be dumped, spread, mixed, watered, rolled and other operations necessary to produce a uniformly blended mixture of the desired course thickness and moisture content. Compaction of each course of material shall be accomplished by suitable equipment to obtain a minimum density of 95% of AASHTO T180-61 (Standard Proctor). Copies of Standard Proctor tests will be submitted to County Engineer for approval before paving.

**10.0 Pavement**

a. Surface Treatment: A two-course asphalt treatment application composed of asphalt material covered with aggregate.

1. Asphalt: Asphalt oils and emulsions shall meet the most current Texas Department of Transportation Standard Specifications, Item 300 Asphalts, Oils And Emulsions.

2. Aggregates: Aggregates shall be from grading as established by the most current Texas Department of Transportation Standard Specifications, Item 302 Aggregates and Surface Treatments.

3. Application Rate and Materials:

First Course

Asphalt, Oils and Emulsions      CRS-2, CRS-2P or HFRS-2P emulsion  
AC-5 or AC-10 @ 0.3 gallons per Sq. Yd.

Aggregate      Type B, Grade 3 @ 1 Cu. Yd./90 Sq. Yd.

Second Course

Asphalt, Oils and Emulsions      CRS-2, CRS-2P or HFRS-2P emulsion  
AC-5 OR AC-10 @ 0.3 gallons per Sq. Yd.

Aggregate      Type B, Grade 4 @ 1 Cu. Yd./110 Sq. Yd

b. Hot Mix Asphalt Concrete Pavement: HMAC pavement shall meet the most current specifications of Texas Department of Transportation Standard Specifications, Item 340

Dense-Graded Hot Mix Asphalt. Minimum compacted depth of one and one-half (1 ½) inch with prime coat.

**11.0 Cattle Guards**

The Commissioners' Court may authorize the installation of cattle guards when considered appropriate for public safety. All cattle guards shall be at least the width of the roadway, but not less than sixteen (16) feet wide, and eight (8) feet in length measured along the center of the road. (See Figure 10 – Details) All cattle guards in subdivisions must be 20 feet wide and supported with a minimum of eight I-beams 4" wide and 12" deep with a web and flange of minimum 3/8" thickness.

**12.0 Cul-de-sacs**

Cul-de-sacs right-of-way shall have a turn around of not less than one-hundred-fifty (150) feet in diameter with a paved area not less than one-hundred (100) feet in diameter.

**13.0 Right-Of-Way**

Minimum right-of-way width for collector and local roads shall be sixty (60) feet and minimum right-of-way width for Arterial roads shall be one hundred (100) feet.

**14.0 Road Jogs**

Whenever possible, road jogs with centerline offsets of less than one hundred and twenty-five (125) feet shall be avoided.

**15.0 Road Intersections**

Road intersections shall be as nearly at right angles as practicable.

**16.0 Non-access Easement**

When deemed necessary, a vehicular non-access easement may be required on a lot for the purpose of controlling ingress and egress to vehicular traffic.

**17.0 Utility Cuts**

All utility cuts shall be approved by County Engineer. (See Figure 6 – Details)

**18.0 Dams and Spillways**

Bandera County will not assume any liability for design, construction or maintenance of any structure used to impound water or over around or next to any structure used to impound water.

**19.0 Signs**

All traffic signs and road name signs shall be furnished by the developer in accordance with the latest issue of the Texas Manual of Uniform Traffic Control Devices (MUTCD) issued by TxDOT and the rules and standards for 9-1-1 Rural Addressing in Bandera County.

**20.0 Mail Delivery Area**

Developer shall provide an engineered mail delivery area adjacent to the road Right-Of-Way.

**DETAILS  
ROAD STANDARDS**



**BANDERA COUNTY  
ARTERIAL ROAD  
28 FOOT PAVEMENT WIDTH**

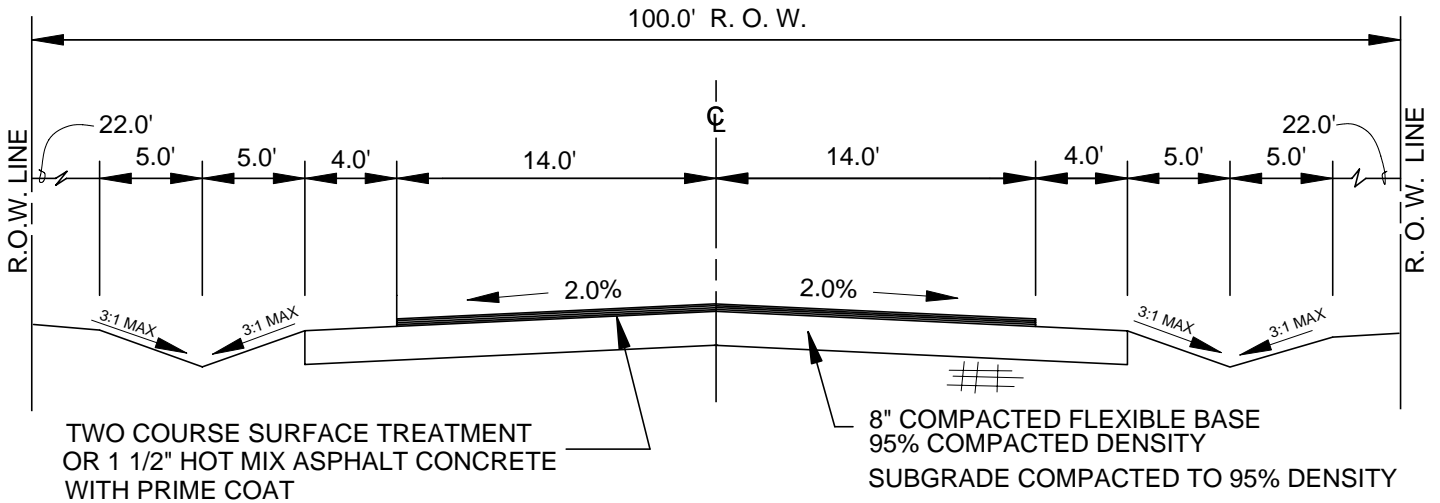

**CROSS SECTION N.T.S.**

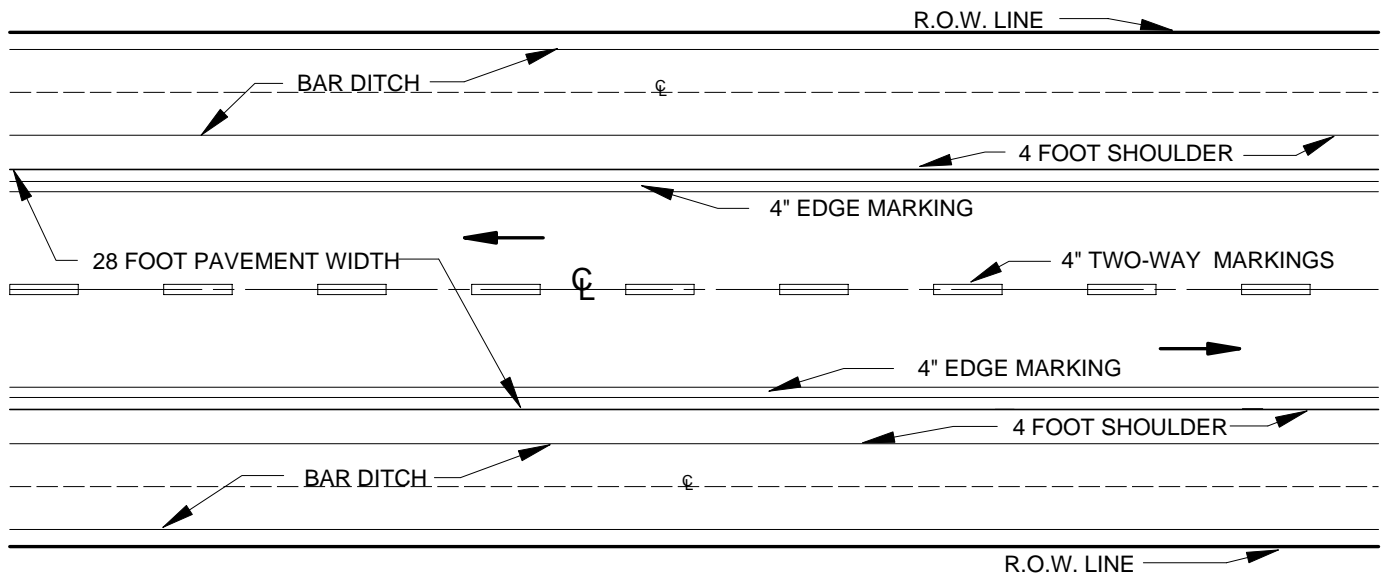

**PLAN VIEW N.T.S.**

**FIGURE 1**

# BANDERA COUNTY COLLECTOR ROAD 24 FOOT PAVEMENT WIDTH

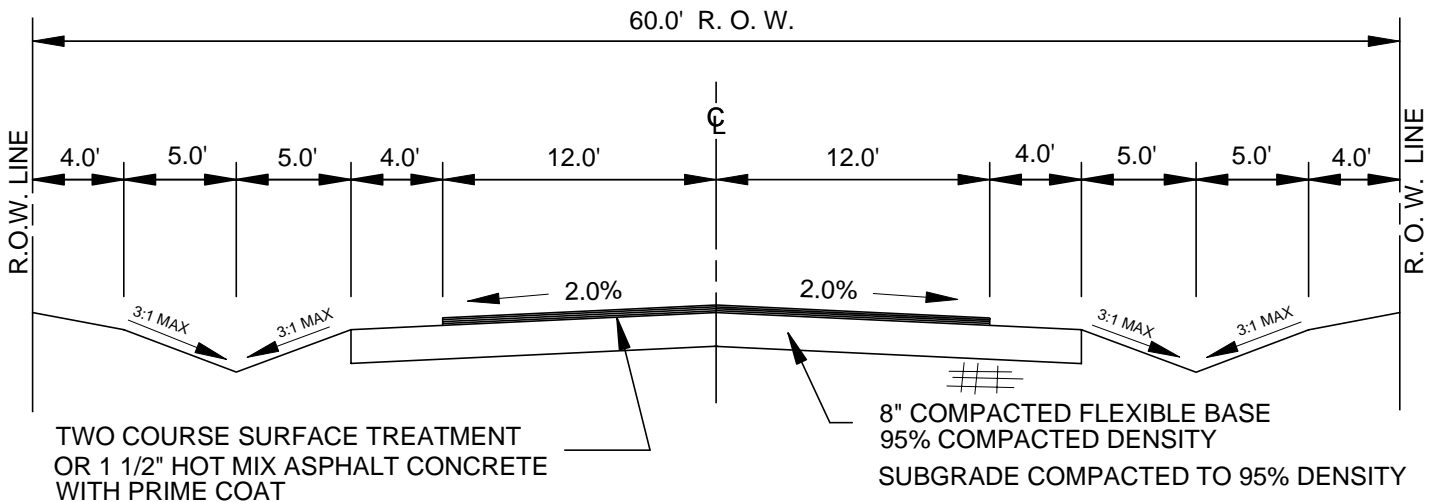

**CROSS SECTION N.T.S.**

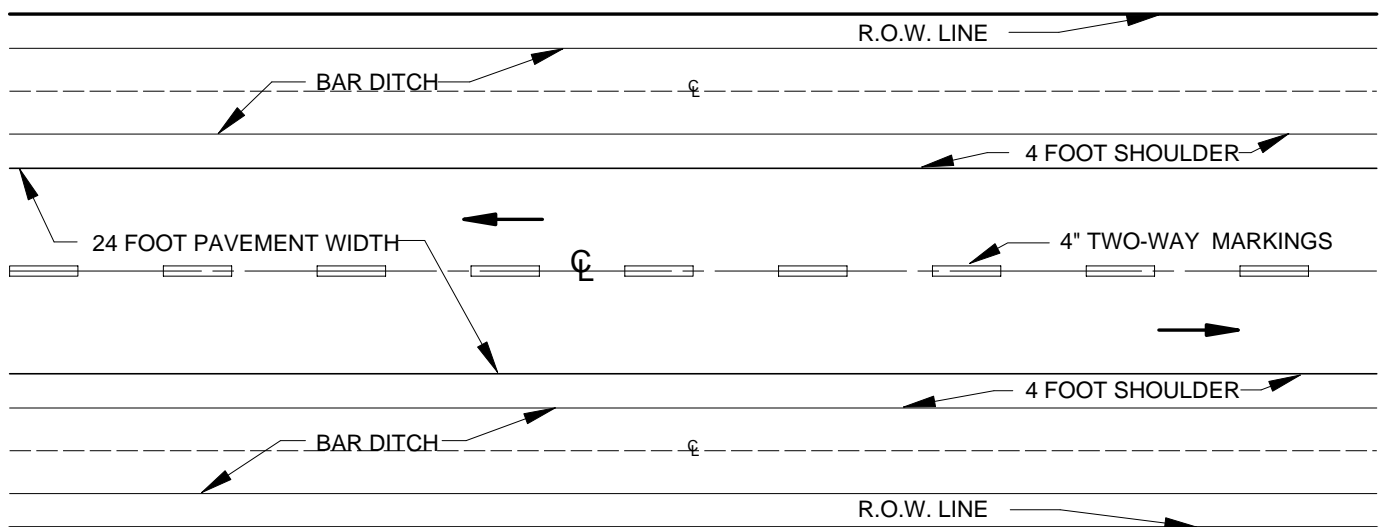

**PLAN VIEW N.T.S.**

**FIGURE 2**

**BANDERA COUNTY  
LOCAL ROAD  
22 FOOT PAVEMENT WIDTH**

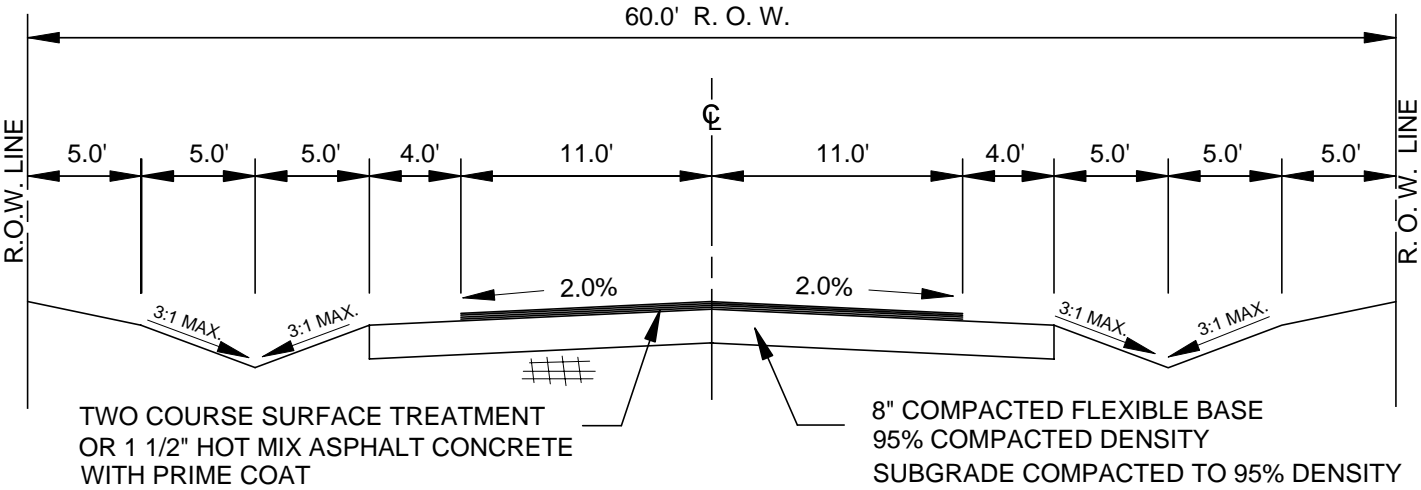

**CROSS SECTION N.T.S.**

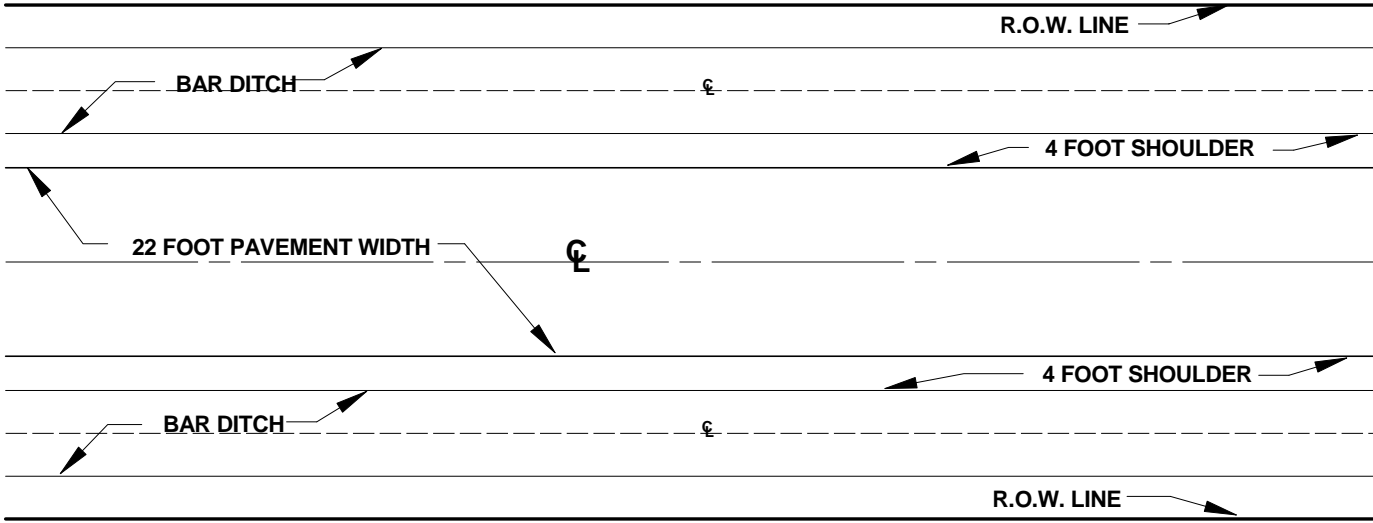

**PLAN VIEW N.T.S.**

**FIGURE 3**

**BANDERA COUNTY  
COLLECTOR OR LOCAL ROAD - CURBED SECTION  
30 FOOT PAVEMENT WIDTH**

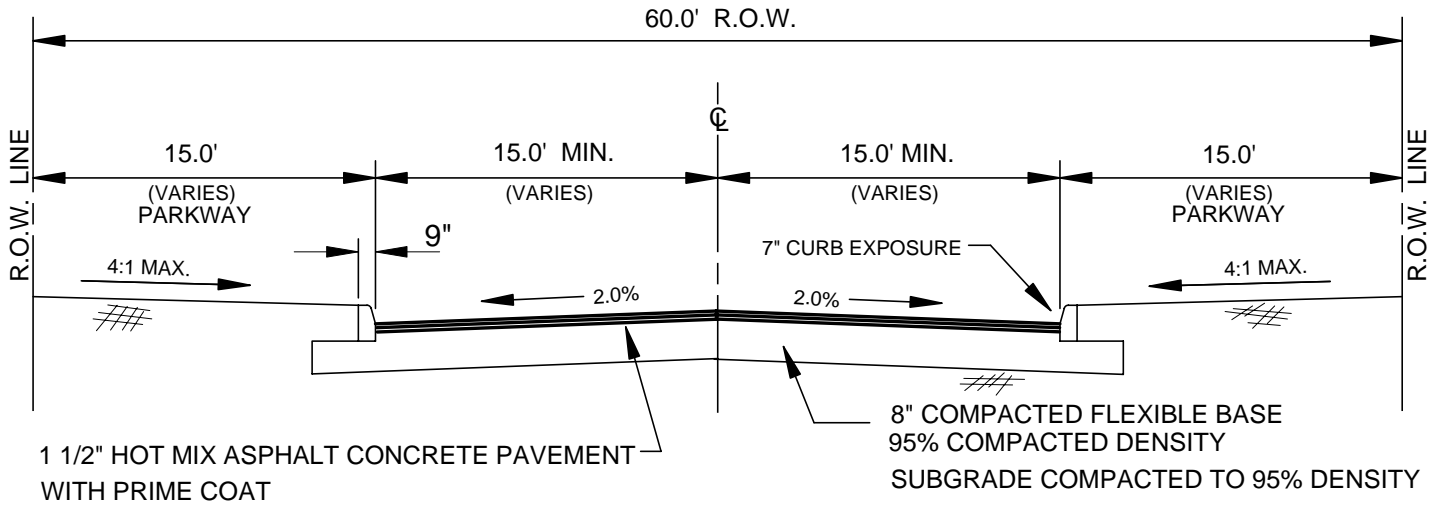

**CROSS SECTION N.T.S.**

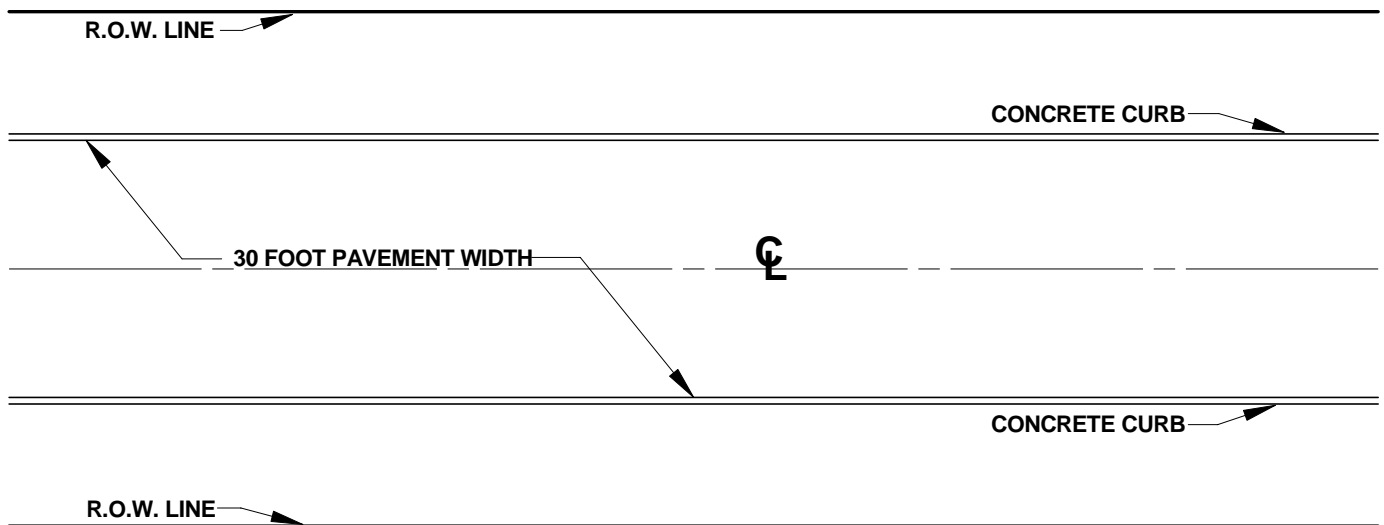

**PLAN VIEW N.T.S.**

**FIGURE 4**

**BANDERA COUNTY  
CUL-DE-SAC TYPICAL DETAIL  
60.0' RIGHT-OF-WAY WITH 22.0' PAVEMENT WIDTH**

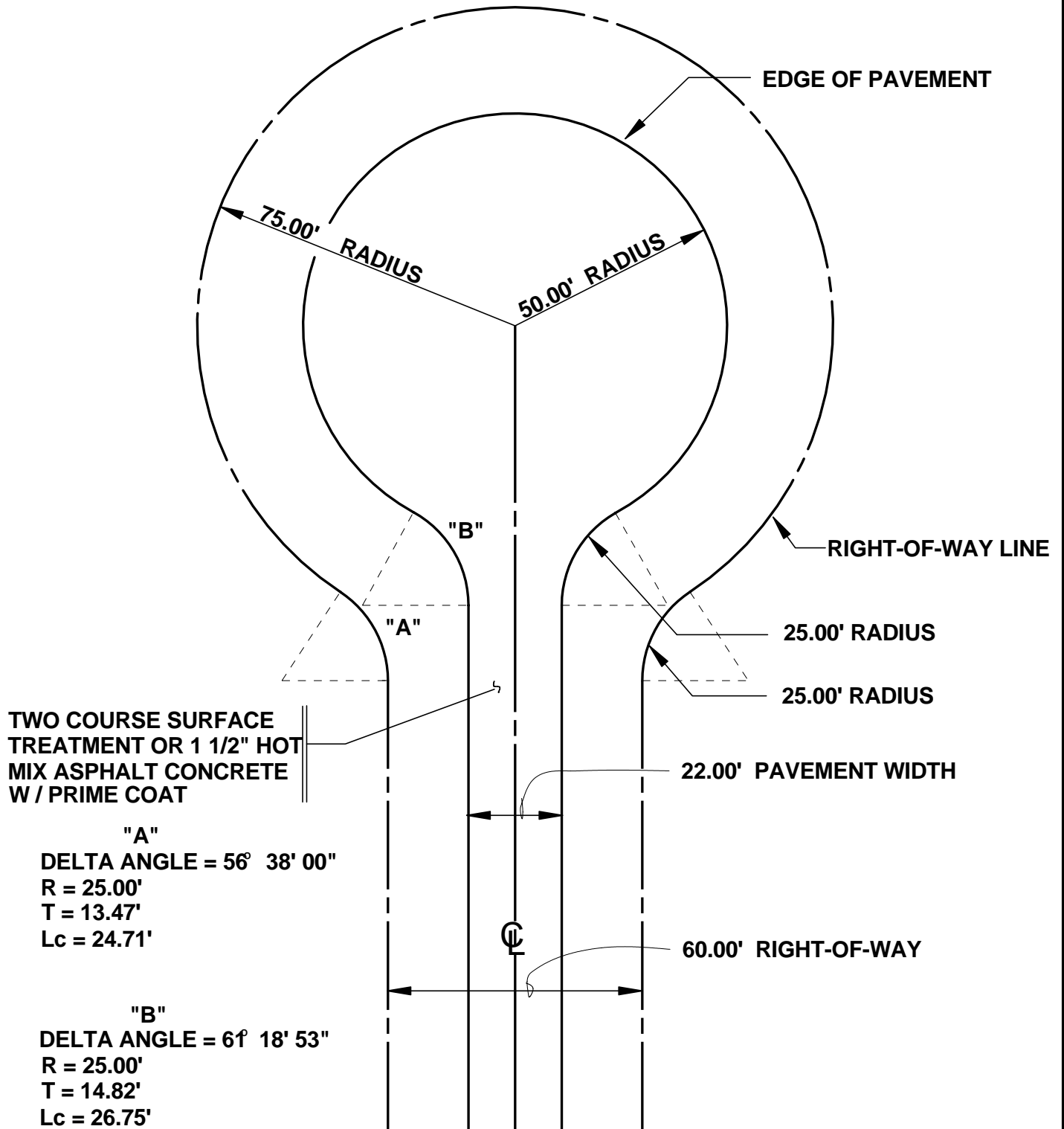

TWO COURSE SURFACE  
TREATMENT OR 1 1/2" HOT  
MIX ASPHALT CONCRETE  
W / PRIME COAT

"A"

DELTA ANGLE = 56° 38' 00"  
R = 25.00'  
T = 13.47'  
Lc = 24.71'

"B"

DELTA ANGLE = 61° 18' 53"  
R = 25.00'  
T = 14.82'  
Lc = 26.75'

N. T. S.  
**FIGURE 5**

# BANDERA COUNTY BASE AND PAVEMENT REPLACEMENT FOR UTILITY CUT

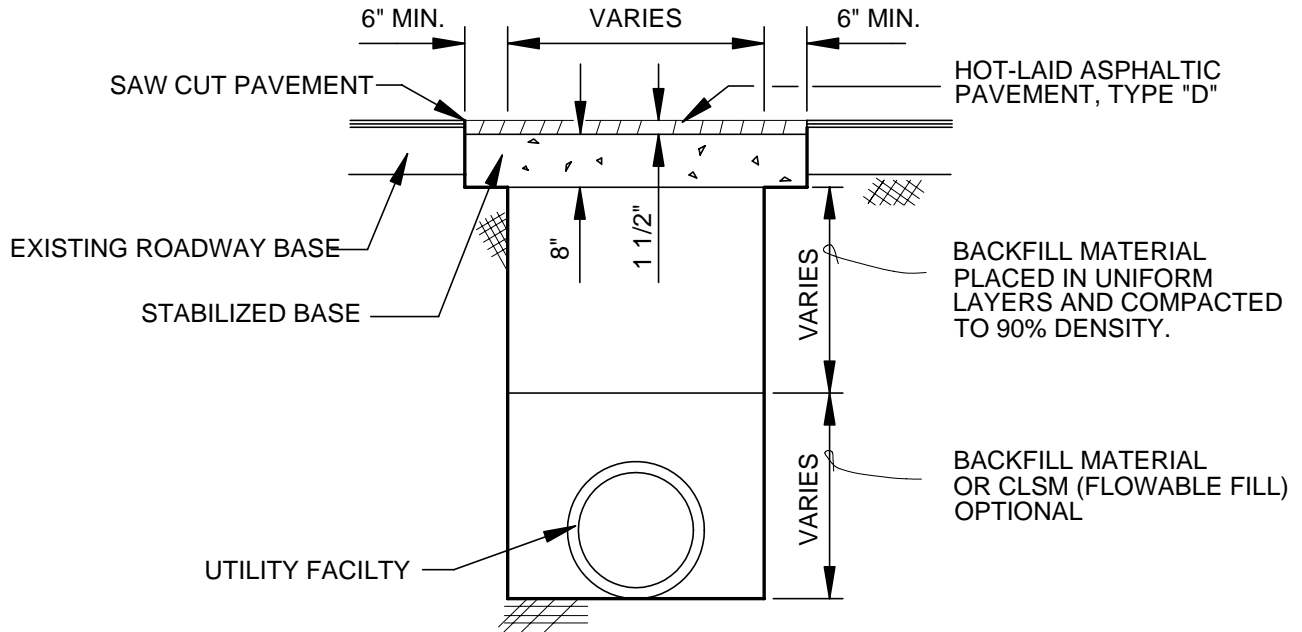

**TRENCH CUT N.T.S.**

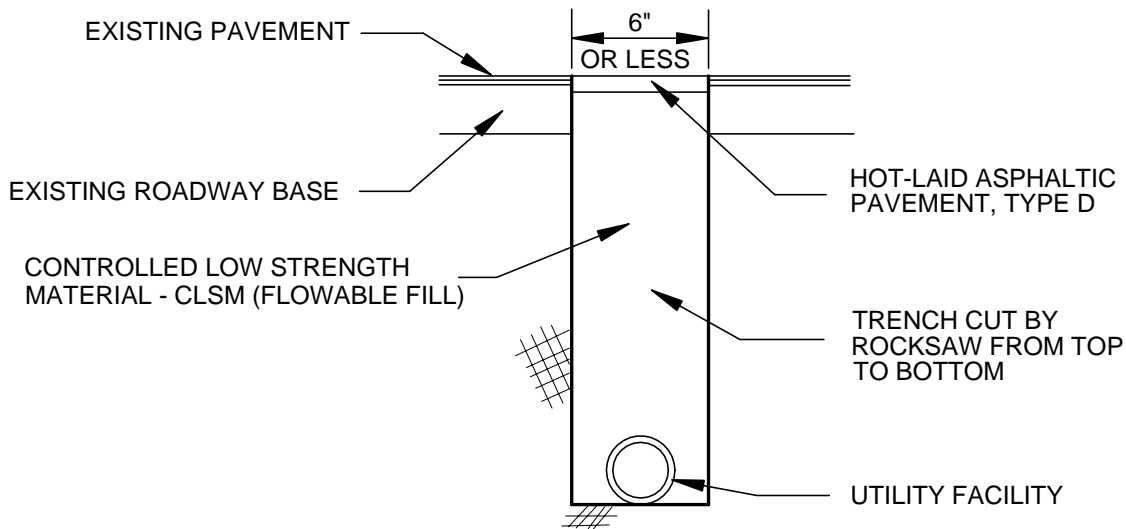

**NARROW TRENCH CUT N.T.S.**

**FIGURE 6**

## BANDERA COUNTY HEADWALLS FOR CULVERTS

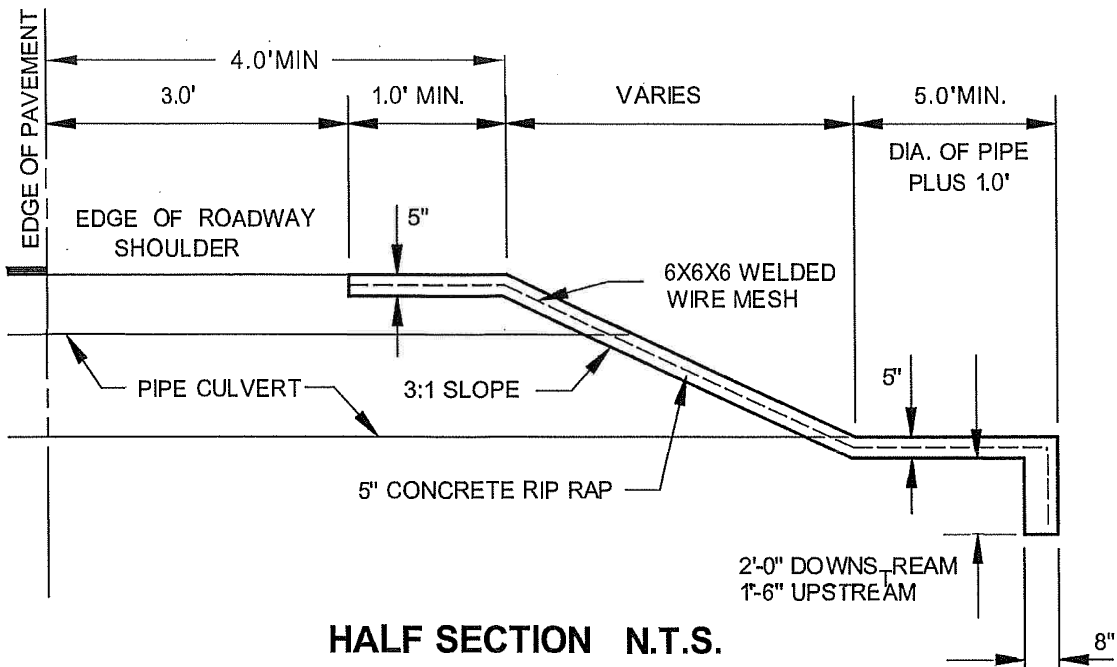

**HALF SECTION N.T.S.**

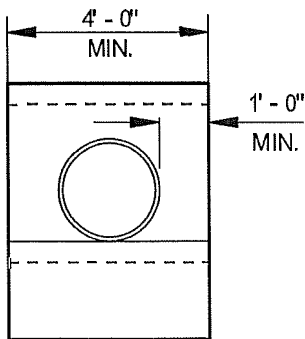

**END VIEW  
N.T.S.**

**NOTES:**

1. 5' CONCRETE RIP RAP, CLASS "A" CONCRETE.
2. IN CASES WHERE A CULVERT WITH ITS HEADWALLS WOULD EXTEND OUTSIDE THE RIGHT-OF-WAY, THE SUBDIVIDER SHALL DEDICATE ADDITIONAL DRAINAGE EASEMENT OR RIGHT-OF-WAY AS REQUIRED TO PROVIDE ACCESS AND EGRESS.

**FIGURE 7**

**BANDERA COUNTY  
INTERCEPTOR DRAINS  
FOR INTERCEPTING SHEET FLOW**

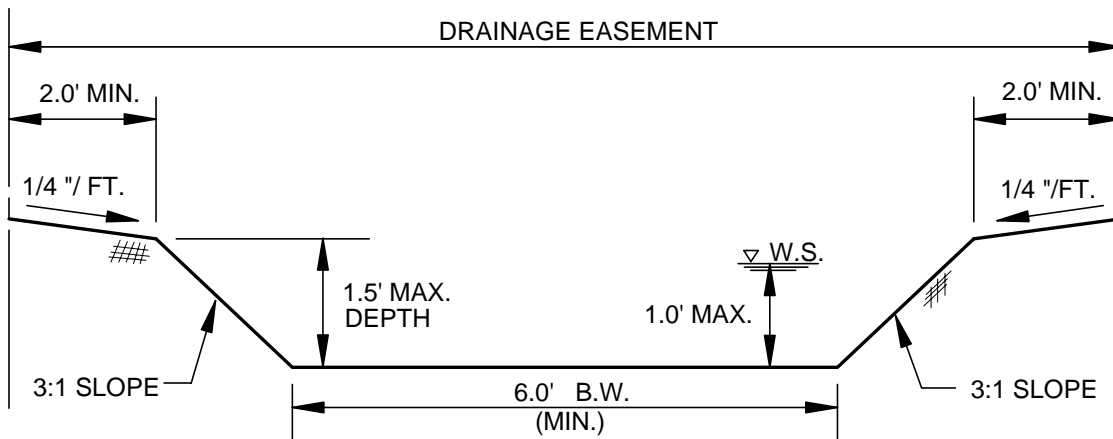

**TRAPEZOIDAL CHANNEL N.T.S.**

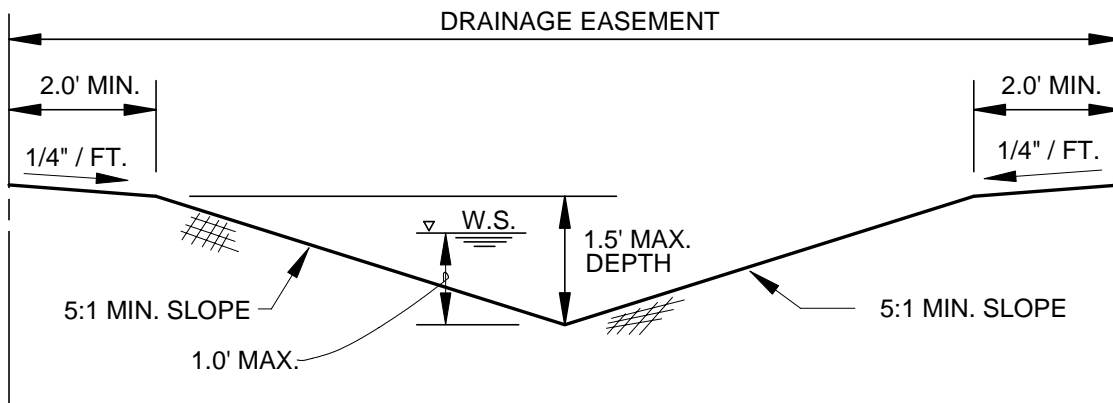

**"V" - SHAPED CHANNEL N.T.S.**

**FIGURE 8**



# BANDERA COUNTY DRIVEWAY AND CULVERT DETAIL

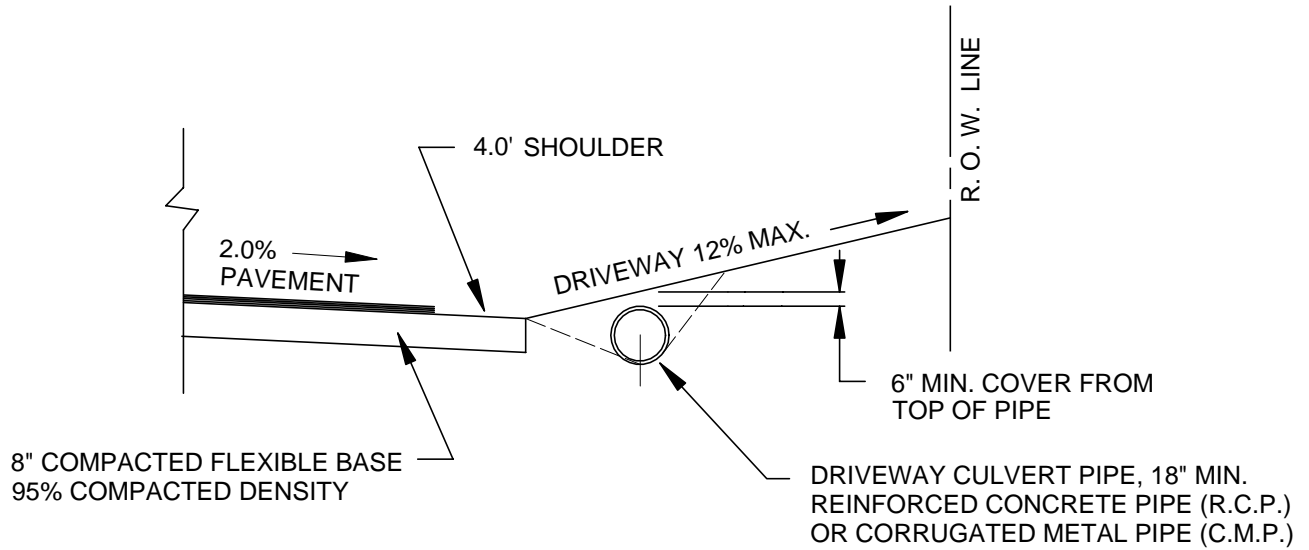

## CROSS SECTION N.T.S.

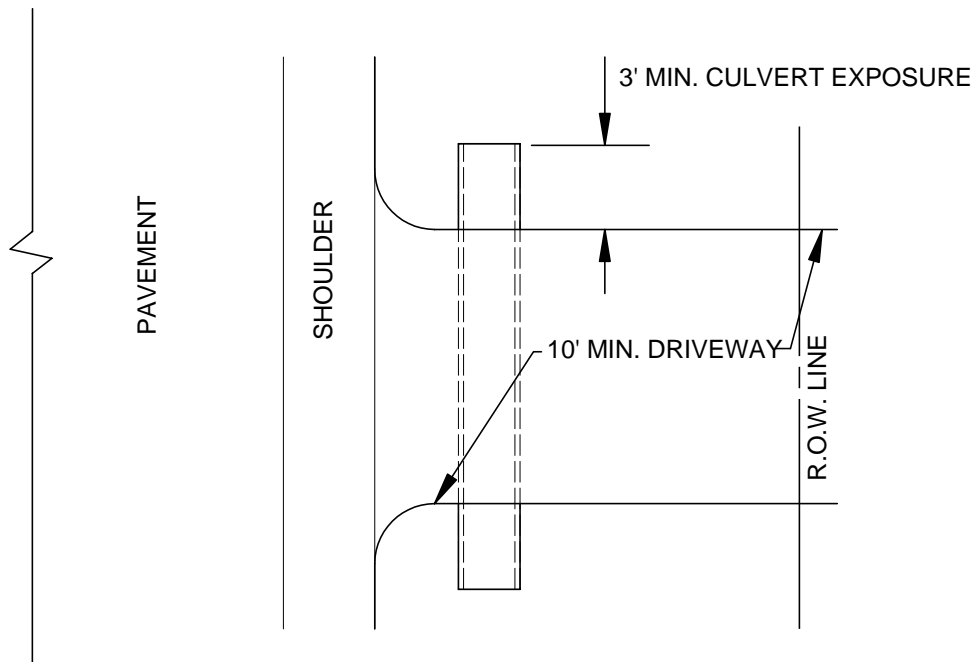

## PLAN VIEW N.T.S.

**FIGURE 9**

# BANDERA COUNTY CATTLE GUARD

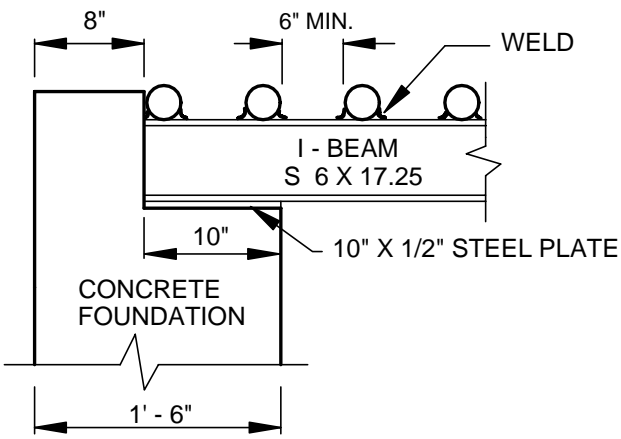
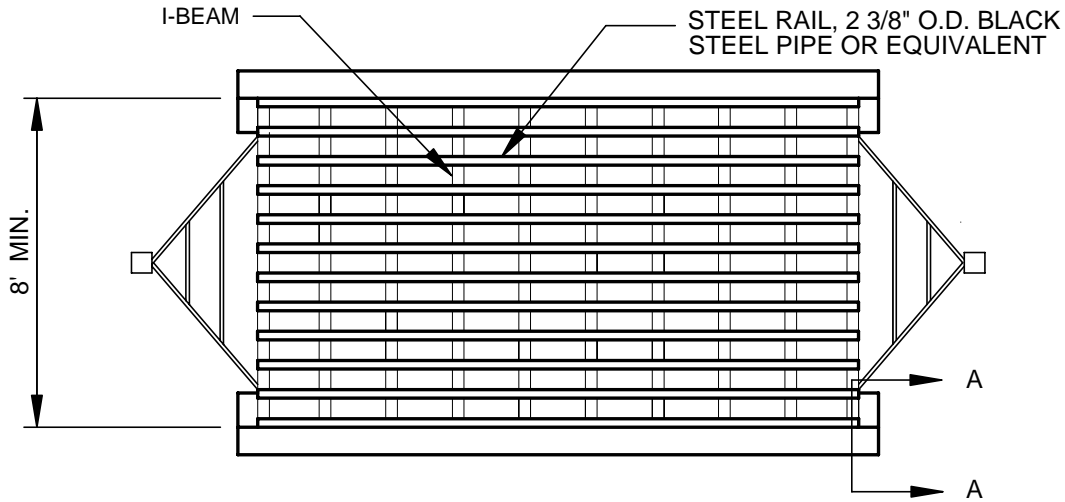
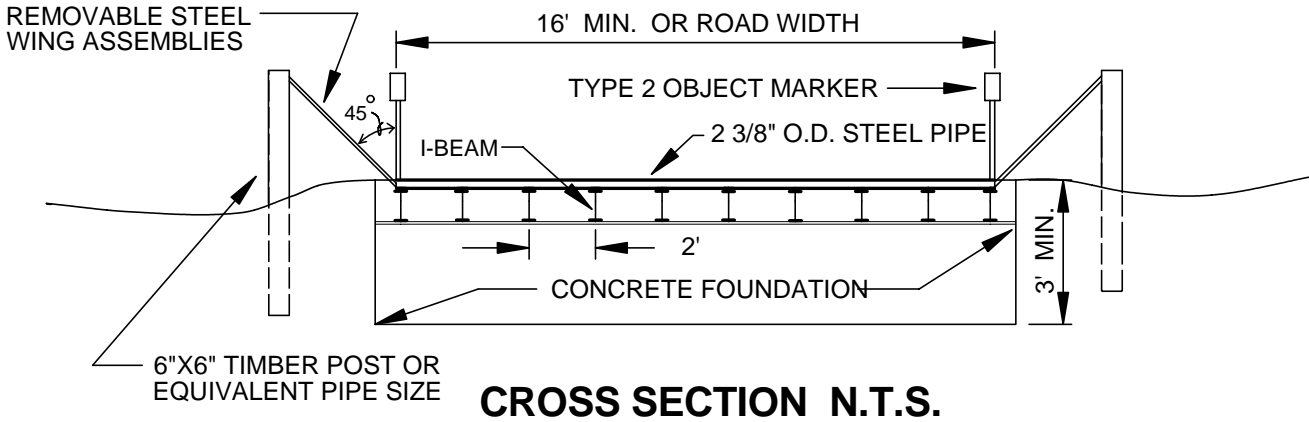

**NOTES:**

1. CONCRETE CLASS "A" SHALL MEET ALL THE REQUIREMENTS AS SET FORTH IN ASTM C-94.
2. ALL STRUCTURAL STEEL SHALL MEET THE REQUIREMENTS AS SET FORTH IN ASTM A-36.
3. ALL BLACK STANDARD STEEL PIPE SHALL MEET REQUIREMENTS AS SET FORTH IN ASTM A-53.
4. ALL I-BEAM SPACING SHALL BE TWO FEET MEASURED CENTER TO CENTER.
5. STEEL RAIL OR STEEL BLACK PIPE SPACING SHALL BE A MINIMUM OF SIX INCHES.
6. WING ASSEMBLIES SHALL BE REMOVABLE.

**FIGURE 10**

## STORM DRAINAGE

### 1.0 Method of Computing Runoff

- a. For drainage areas less than six hundred forty (640) acres, the basis for computing runoff shall be the rational formula or some other method provided it is acceptable to the County Engineer:

$Q = CIA$ ; where:

Q = Runoff in cubic feet per second

C = Coefficient of runoff

I = Intensity of rainfall in inches per hour

A = Drainage area in acres

- b. Drainage areas six hundred forty (640) acres or greater, the basis for computing runoff shall be a unit hydrograph, preferably the Soil Conservation Service (SCS) TR-20 method as contained in the U.S Army Corps of Engineers Hydrologic Engineering Center HEC-1 “flood Hydrograph Package.”

### 2.0 Runoff Calculations

- a. In all cases, wet antecedent conditions shall be assumed.
- b. For drainage areas less than six hundred forty (640) acres, runoff rates shall be computed at not less than the following:

**TABLE 5**  
**Average Runoff Percentage**

Character of Area	Slope			
	Up to 1.0%	Over 1.0% to 3.0%	Over 3.0% to 5.0%	Over 5.0%
Business or commercial areas (90% or more impervious)	95	96	97	97
Densely developed areas (80% to 90% impervious)	85	88	91	95
Closely built residential areas and school sites	75	77	80	84
Undeveloped areas	68	70	72	75
Cultivated	35	60	80	90
Average residential areas	65	67	69	72

**TABLE 6**  
**Manning's Roughness Coefficient**

<u>Channel Description</u>	<u>Manning's "n" Value</u>
Concrete Lined Channel	0.015
Grass Lined Channel with regular maintenance	0.035
Grass Lined Channel without recent maintenance	0.050
Vegetated Channel with trees, little or no underbrush	0.055
Natural Channel with trees, moderate underbrush	0.075
Natural Channel with trees, dense underbrush	0.090
<u>Overbank Description</u>	<u>Manning's "n" Value</u>
Pasture	0.050 - 0.055
Trees, little or no underbrush, scattered structures	0.060 - 0.075
Dense vegetation, multiple fences and structures	0.075 - 0.090

- c. Runoff rates shall be computed on the basis of ultimate development of the entire watershed of the proposed development.

**3.0 Concrete Lined Channels**

- a. The design of concrete lined channels shall be based on a twenty-five (25) year frequency. The design is subject to the approval of the County Engineer and shall comply with the following requirements.

**TABLE 7**  
*Drainage Freeboard for Channels*

<u>Design Depth of Flow</u>	<u>Required Freeboard</u>
0 to 5 feet	0.5 foot
5 to 10 feet	10% of design depth
10 feet and over	1.0 foot

- b. From the top of the concrete lining to the top of the ditch, a maximum side slope of two (2) horizontal to one (1) vertical shall be required. The side slope will have a minimum of twelve (12) to one (1).

- d. For normal conditions, the concrete lining shall be a minimum of five (5) inches thick and reinforced with No. 3 round bars placed at eighteen (18) inches on center both directions.

#### **4.0 Earth Channels**

- a. The design of earth channels shall be based on a twenty-five (25) year frequency subject to the approval of the County Engineer.
- b. The depth of the earth channel shall be for the design depth of flow plus the required freeboard.
- c. The side slopes shall not be steeper than three (3) horizontal to one (1) vertical.

#### **5.0 Drainage Structures**

All drainage structures shall be based on a twenty-five (25) year frequency subject to the approval of the County Engineer. Drainage structures include low water crossings, culverts, and bridges. Drainage plans shall be prepared by a registered Professional Engineer experienced in hydrology analysis, and shall be signed and sealed. Whenever possible concrete multiple box culverts having a minimum span of twenty (20) feet measured from inside wall to inside wall with a minimum height of two (2) feet shall be used.

#### **6.0 Roadway Ditches**

Ditches intended for parallel drainage shall be designed to accommodate runoff to be expected at a two (2) year frequency.

#### **7.0 Driveway Culvert Pipe**

No pipe less than eighteen (18) inches in diameter or comparable flow shall be used for driveway crossings. (See Figure 9 – Details)

- a. No culvert
- b. If culvert required, pipe size will be recommended by County Engineer or designed by a Professional Engineer. Owner may appeal to Commissioners' Court in the event of a disagreement between County Engineer and Professional Engineer.

**APPENDIX C**  
**CERTIFICATION**  
**OF**  
**GROUNDWATER AVAILABILITY FOR PLATTING FORM**

---

*Use of this for: If required by a county authority pursuant to §232.0031, Local Government Code, the plat applicant and the Texas licensed professional engineer or geoscientist shall use this form based upon the requirements of Title 30, Texas Administrative Code, Chapter 230 to certify that adequate groundwater is available under the land to be subdivided (if the source of water for the subdivision is groundwater under the subdivision) for any subdivision subject to platting under §232.001, Local Government Code. The form and Chapter 230 do not replace state requirements applicable to public drinking water systems or the authority of counties or groundwater conservation districts under either §35.019 or Chapter 36 of the Texas Water Code*

---

**Administrative Information (30 TAC, §230.4).** Article Four: Water Availability section 4.3, Bandera County Subdivision and Land Development Rules and Regulations.

1. Name of Proposed Subdivision: \_\_\_\_\_
2. Any Previous Name Which Identifies the Tract of Land: \_\_\_\_\_  
\_\_\_\_\_
3. Property Owner's Name(s): \_\_\_\_\_  
Address: \_\_\_\_\_  
Phone: \_\_\_\_\_  
Fax: \_\_\_\_\_
4. Plat Applicant's Name: \_\_\_\_\_  
Address: \_\_\_\_\_  
Phone: \_\_\_\_\_  
Fax: \_\_\_\_\_
5. Licensed Professional Engineer's Name or Texas Licensed Professional Geoscientist: \_\_\_\_\_  
\_\_\_\_\_  
Address: \_\_\_\_\_



**Projected Water Demand Estimate (30 TAC, §230.6).** Article Four: Water Availability section 4.5, Bandera County Subdivision and Land Development Rules and Regulations.

- a. Residential Water Demand Estimate at Full Build Out (includes both single family and multi-family residential).

Number of Proposed Housing Units (single and multi-family): \_\_\_\_\_

Average Number of Persons per Housing Unit: \_\_\_\_\_

Gallons of Water Required per Person per Day: \_\_\_\_\_

Water Demand per Housing Unit per year (acre feet/year): \_\_\_\_\_

Total Expected Residential Water Demand per Year (acre feet/year): \_\_\_\_\_

14. Non-residential Water Demand Estimate at Full Build Out.

Type(s) of Non-residential Water Uses: \_\_\_\_\_

Water Demand per Type per Year (acre feet/year): \_\_\_\_\_

15. Total Water Demand Estimate at Full Build Out (acre feet/year): \_\_\_\_\_

16. Sources of Information Used for Demand Estimates: \_\_\_\_\_

---

**General Groundwater Resource Information (30 TAC, §230.7).** Article Four: Water Availability section 4.6, Bandera County Subdivision and Land Development Rules and Regulations.

17. Identify and describe, using Texas Water Development Board names, the aquifer(s) which underlies the proposed subdivision: \_\_\_\_\_

*Note: Users may refer to Aquifers of Texas (Texas Water Development Board Report 345, 1995) to obtain general information pertaining to the state's aquifers. This reference is available via the internet ([www.twdb.state.tx.us](http://www.twdb.state.tx.us)).*

---

**Obtaining Site-Specific Groundwater Data (30 TAC, §230.8).** Article Four: Water Availability section 4.7, Bandera County Subdivision and Land Development Rules and Regulations.

18. Have all known existing, abandoned, and inoperative wells within the proposed subdivision been located, identified, and shown on the plat as required under §230.8(b)?                      Yes      No





Hydraulic conductivity: \_\_\_\_\_

Were any recharge or barrier boundaries detected? Yes      No

If yes, please describe: \_\_\_\_\_

Thickness of aquifer(s): \_\_\_\_\_

30. Have time-drawdown determinations been calculated as required under §230.10(d)(1)? Yes      No
31. Have distance-drawdown determinations been calculated as required under §230.10(d)(2)? Yes      No
32. Have well interference determinations been made as required under §230.10(d)(3)? Yes      No
33. Has the anticipated method of water delivery, the annual groundwater demand estimates at full build out, and the geologic and groundwater information been taken into account in making these determinations? Yes      No
34. Has the water quality analysis required under §230.9 been compared to primary and secondary public drinking water standards as required under §230.10(e)? Yes      No
- Does the concentration of any analyzed constituent exceed the standards? Yes      No
- If yes, please list the constituents(s) and concentration measure(s), which exceed standards: \_\_\_\_\_

---

**Groundwater Availability and Usability Statements (30 TAC, §230.11 (a) and (b)).** Article Four:

Water Availability section 4.10, Bandera County Subdivision and Land Development Rules and Regulations.

35. Drawdown of the aquifer at the pumped well(s) is estimated to be \_\_\_\_\_ feet over a 10-year period and \_\_\_\_\_ feet over a 30-year period.
36. Drawdown of the aquifer at the property boundary is estimated to be \_\_\_\_\_ feet over a 10-year period and \_\_\_\_\_ feet over a 30-year period.
37. The distance from the pumped well(s) to the outer edges of the con(s)-of-depression is estimated to be \_\_\_\_\_ feet over a 10-year period and \_\_\_\_\_ feet over a 30-year period.
38. The recommended minimum spacing limit between wells is \_\_\_\_\_ feet with a recommended well yield of \_\_\_\_\_ gallons per minute per well.
39. Available groundwater is / is not (circle one) of sufficient quality to meet the intended use of the platted subdivision.

40. The groundwater availability determination does not consider the following conditions (identify any assumptions or uncertainties that are inherent in the groundwater availability determination):

---

---

**Certification of Groundwater Availability (30 TAC, §230.11(c)). Must be signed by a Texas Licensed Professional Engineer or Texas Licensed Professional Geoscientist.** Article Four: Water Availability section 4.10, Bandera County Subdivision and Land Development Rules and Regulations.

41. I, \_\_\_\_\_, Texas Licensed Professional Engineer/Texas Licensed Professional Geoscientist, certificate number \_\_\_\_\_, based on best professional judgment, current groundwater conditions, and the information developed and presented in this form, certify that adequate groundwater is available from the underlying aquifer(s) to supply the anticipated use of the proposed subdivision.

Date: \_\_\_\_\_

(affix seal)

**APPENDIX D**  
**Commissioners' Court Signature Block**

A signature block shall be inscribed on the first plat sheet as follows:

STATE OF TEXAS           §

COUNTY OF BANDERA   §

Approved by the Commissioners' Court of Bandera County, Texas this  
\_\_\_\_\_ day of \_\_\_\_\_, A.D., 20\_\_\_\_.

---

County Judge, Bandera County, Texas

---

Commissioner, PCT. No. 1

---

Commissioner, PCT. No. 2

---

Commissioner, PCT. No. 3

---

Commissioner, PCT. No. 4

**APPENDIX E**

**Ad Valorem Tax Affidavit**

AFFIDAVIT

THE STATE OF TEXAS §

COUNTY OF BANDERA §

BEFORE ME, the undersigned authority on this day personally appeared \_\_\_\_\_,  
who being duly sworn says:

In compliance with Texas H.B. 1563, effective September 1, 1999, I certify that all Ad valorem Taxes  
due on the following:

have been paid as evidenced by the attached tax Certificates from all taxing agencies having jurisdiction  
over this property.

I further attest that the above information is true and correct. Further affiant sayeth not.

\_\_\_\_\_

\_\_\_\_\_

Owner and/or Developer

SUBSCRIBED AND SWORN to before me this \_\_\_\_\_ day of \_\_\_\_\_, 20\_\_\_\_.

\_\_\_\_\_

Notary Public, State of Texas

Commission expires: \_\_\_\_\_

NOTICE: The foregoing Affidavit must be filed in the official public records of Bandera County, Texas.

## **APPENDIX F**

### **County Clerk's Certification**

CERTIFICATION

STATE OF TEXAS §  
COUNTY OF BANDERA §

I, \_\_\_\_\_, COUNTY CLERK OF SAID COUNTY, DO HEREBY CERTIFY THAT THE FOREGOING INSTRUMENT OF WRITING WITH ITS CERTIFICATE OF AUTHENTICATION WAS FILED FOR RECORD IN MY OFFICE ON THE \_\_\_\_\_ DAY OF \_\_\_\_\_, A.D. 20\_\_\_\_, AT \_\_\_\_\_ O’CLOCK \_\_M. IN THE PLAT RECORDS OF SAID COUNTY IN BOOK \_\_\_\_\_ PAGE \_\_\_\_\_.

TAX CERTIFICATE AFFIDAVIT FILED THIS DATE IN VOLUME \_\_\_\_\_, PAGE \_\_\_\_\_, BANDERA COUNTY DEED RECORDS.

IN TESTIMONY WHEREOF, WITNESS MY HAND AND OFFICIAL SEAL OF OFFICE THIS \_\_\_\_\_ DAY OF \_\_\_\_\_ A.D. 20\_\_\_\_\_.

\_\_\_\_\_  
COUNTY CLERK, BANDERA COUNTY, TEXAS

NOTICE: The foregoing Statement must appear on all preliminary and final subdivision plats prior to plat approval.



## **APPENDIX G**

### **Bandera Electric Cooperative, Inc. Utility Easement Note**

**Bandera Electric Cooperative, Inc.**  
**Utility Easement Note**

It is understood and agreed that perpetual easements are reserved for the installation and maintenance of utilities and all necessary appurtenances thereto, whether installed in the air, upon the surface or underground, along and within ten (10') of the rear, front and side lines of all lots and/or tracts and in the streets, alleys, boulevards, lanes, and roads of this subdivision, and ten feet (10') along the outer boundaries of all streets, alleys, boulevards, lanes, and roads where subdivision lines or lots of individual tracts are deeded to the center line of the roadway. Nothing shall be placed or permitted to remain within the easement areas which may damage or interfere with the installation and maintenance of utilities. The easement area of each lot and all improvements within it shall be maintained by the owner of the lot, except for those facilities for which an authority or utility company is responsible. Utility companies or their employees shall have all of the rights and benefits necessary or convenient for the full enjoyment of the rights herein granted, including but limited to the free right of ingress to and egress from the right-of-way and easement, and the right from time to time to cut all trees, undergrowth and other obstructions that may injure, endanger or interfere with the operation of said utility facilities. The easement rights herein reserved include the privilege of anchoring any support cables or other devices outside said easement when deemed necessary by the utility to support equipment within said easement and the right to install wires and/or cables over some portions of said lots/or tracts not within said easement so long as such items do not prevent the construction of buildings on any of the lots and/or tracts of this subdivision.

## **APPENDIX H**

### **Application for Subdivision Approval**

**Application for Subdivision Approval**  
**Bandera County, Texas**

This form must be filled out in its entirety and submitted along with all documents required by the Bandera County Subdivision and Development Rules.

PROPOSED NAME OF SUBDIVISION: \_\_\_\_\_

PRECINCT IN WHICH THE SUBDIVISION LIES: \_\_\_\_\_

PRECINCT COMMISIONER: \_\_\_\_\_

NAME OF PROPERTY OWNER(s): \_\_\_\_\_

Address: \_\_\_\_\_

Telephone No: \_\_\_\_\_

NAME OF APPLICANT(s): \_\_\_\_\_

Company: \_\_\_\_\_

Address: \_\_\_\_\_

Telephone No: \_\_\_\_\_

NAME OF LIEN HOLDER(s): \_\_\_\_\_

Company: \_\_\_\_\_

Address: \_\_\_\_\_

Telephone No: \_\_\_\_\_

DATE PLAT FILED: \_\_\_\_\_

TOTAL ACREAGE OF DEVELOPMENT: \_\_\_\_\_ TOTAL ACREAGE OF LOTS: \_\_\_\_\_

INTENDED USE OF LOTS:

Residential: \_\_\_\_\_ Commercial/Industrial: \_\_\_\_\_

TOTAL NUMBER OF LOTS: \_\_\_\_\_ SMALLEST LOT'S ACREAGE: \_\_\_\_\_

FRONTAGE ON EXISTING ROAD: \_\_\_\_\_

COUNTY ROAD: \_\_\_\_\_

STATE ROAD: \_\_\_\_\_

OTHER ROAD: \_\_\_\_\_

PROPERTY ADDRESS/LOCATION: \_\_\_\_\_

CURRENT LEGAL DESCRIPTION: \_\_\_\_\_

CURRENT LAND AREA: \_\_\_\_\_ ACRES

CITY ETJ: \_\_\_\_\_ (no) \_\_\_\_\_ (yes) City Name: \_\_\_\_\_

IS THERE FLOODPLAIN WITHIN SUBDIVISION BOUNDARY? YES: \_\_\_\_\_ NO: \_\_\_\_\_

SCHOOL DISTRICT(S): \_\_\_\_\_

NEW ROADS IN DEVELOPMENT:

PUBLIC ROADS: \_\_\_\_\_

PRIVATE ROADS: \_\_\_\_\_

SOURCE OF WATER: \_\_\_\_\_

(PUBLIC WATER SUPPLY, RAINWATER CATCHMENT, PRIVATE WELL, SHARED WELL)

Water Availability check or note?

ANTICIPATED WASTEWATER SYSTEM: \_\_\_\_\_

(CONVENTIONAL SEPTIC SYSTEM, CLASS I PERMITTED SYSTEM, COLLECTIVE SANITARY SEWER)

FINAL PLAT WITH STREETS OR DRAINAGE IMPROVEMENTS ONLY

FISCAL SECURITY TYPE: \_\_\_\_\_

FISCAL SECURITY EXPIRATION DATE (if applicable): \_\_\_\_\_

Note: See County Clerk for a list of County Officials (Judge, Commissioners' and their addresses)

## **APPENDIX I**

### **Preliminary Plat Checklist**

**Preliminary Plat Checklist**  
**Bandera County, Texas**

**SUBDIVISION NAME:** \_\_\_\_\_

**APPLICATION MATERIALS:**

- Seven blueline copies of plat
- Application fees
- Tax certificate
- Letter from 911 Addressing Department  
(Approving road names)
- Completed subdivision application
- Letter of water/wastewater availability
- Letter from Bandera Electric Cooperative
- Letter from lien holder, acknowledgment
- Construction plans for streets and drainage

**GENERAL INFORMATION:**

- |   |                          |                    |
|---|--------------------------|--------------------|
| Subdivision name                          | <input type="checkbox"/> | Comments:<br>_____ |
| Boundary lines/total acreage              | <input type="checkbox"/> | _____              |
| Number of lots/size categories            | <input type="checkbox"/> | _____              |
| Acreage & dimensions of lots              | <input type="checkbox"/> | _____              |
| Parks, squares, greenbelts, schools, etc. | <input type="checkbox"/> | _____              |
| Adjoining subdivisions/property owners    | <input type="checkbox"/> | _____              |
| Name & address or surveyor/engineer       | <input type="checkbox"/> | _____              |
| Name & address of owner/application       | <input type="checkbox"/> | _____              |
| Area map showing general location         | <input type="checkbox"/> | _____              |
| North arrow, scale and date               | <input type="checkbox"/> | _____              |
| Boundary lines of cities and ETJs         | <input type="checkbox"/> | _____              |

School district note or boundaries  \_\_\_\_\_

**FLOODPLAIN & DRAINAGE INFORMATION:**

Comments: \_\_\_\_\_

Elevation contours (1'/NGVD '83)  \_\_\_\_\_

FEMA flood hazard areas  \_\_\_\_\_

Additional 100-year flood contours  \_\_\_\_\_

100-year flood benchmark & lat/long  \_\_\_\_\_

Drainage plan  \_\_\_\_\_

Location & size of drainage structures  \_\_\_\_\_

Streams, rivers, ponds, lakes  \_\_\_\_\_

**STREETS & RIGHT OF WAY INFORMATION:**

Location, length and ROW widths  \_\_\_\_\_

Location, size of easements/driveways  \_\_\_\_\_

Number of feet road frontage on each lot  \_\_\_\_\_

Location of depth gauges (100-year flood)  \_\_\_\_\_

**WATER, WASTEWATER, UTILITIES INFORMATION:**

Electric, phone, gas, utility providers  \_\_\_\_\_

Location of utility easements  \_\_\_\_\_

Water & sewer utility providers  \_\_\_\_\_

On-site sewage facility planning report  \_\_\_\_\_

Water Availability Certification  \_\_\_\_\_



## **APPENDIX J**

### **Final Plat Checklist**

## Final Plat Checklist

### Bandera County, Texas

**SUBDIVISION NAME:** \_\_\_\_\_

**APPLICATION MATERIALS:**

Comments:

- |  |                          |  |
|--|--------------------------|--|
| Eight (8) blackline copies of plat   | <input type="checkbox"/> |  |
| One original mylar of plat with signatures/seals   | <input type="checkbox"/> |  |
| Electronic copy of plat<br>(copy must be in pdf format in a version no earlier than<br>one version from current) | <input type="checkbox"/> |  |
| Application fees   | <input type="checkbox"/> |  |
| Tax certificate(s)   | <input type="checkbox"/> |  |
| Letter from 911 Rural Addressing Department  | <input type="checkbox"/> |  |
| Letter from lien holder, acknowledgment  | <input type="checkbox"/> |  |
| Completed subdivision application  | <input type="checkbox"/> |  |
| Utility Checklist  | <input type="checkbox"/> |  |
| Construction fiscal surety   | <input type="checkbox"/> |  |
| Letter of water/wastewater availability  | <input type="checkbox"/> |  |
| Construction plans for streets/drainage (approved)   | <input type="checkbox"/> |  |
| Street name and traffic regulatory sign checklist  | <input type="checkbox"/> |  |

**GENERAL INFORMATION:**

Comments:

- |                             |                          |  |
|-----------------------------|--------------------------|--|
| Final plat requirements     | <input type="checkbox"/> |  |
| Bearings & dimensions       | <input type="checkbox"/> |  |
| Monumentation description   | <input type="checkbox"/> |  |
| Location to original survey | <input type="checkbox"/> |  |
| Lot & block numbers         | <input type="checkbox"/> |  |
| Acreage of all lots         | <input type="checkbox"/> |  |

**FLOODPLAIN & DRAINAGE INFORMATION:**

- |   |                          |  |
|---|--------------------------|--|
| 100-yr benchmarks & finish floor elevations | <input type="checkbox"/> |  |
| 100-year monument lat/long                  | <input type="checkbox"/> |  |

**STREETS & RIGHT OF WAY INFORMATION:**

Comments:

- Length of streets
- Total area of ROW dedicated to public
- Minimum driveway culvert size

---



---



---

**WATER, WASTEWATER, UTILITIES INFORMATION:**

- Viable percolation area
- Water supply warning statement
- Wastewater permit statement
- Utility easements:
  - Electric
  - Telephone
  - Gas
  - Water
  - Sewer
  - Pipeline

---



---



---



---



---



---



---



---



---

**WATER AVAILABILITY:**

---

**OTHER PLAT NOTES:**

- Development permit statement

---

## APPENDIX K

### Bandera County

### Subdivision Process Summary

(optional)

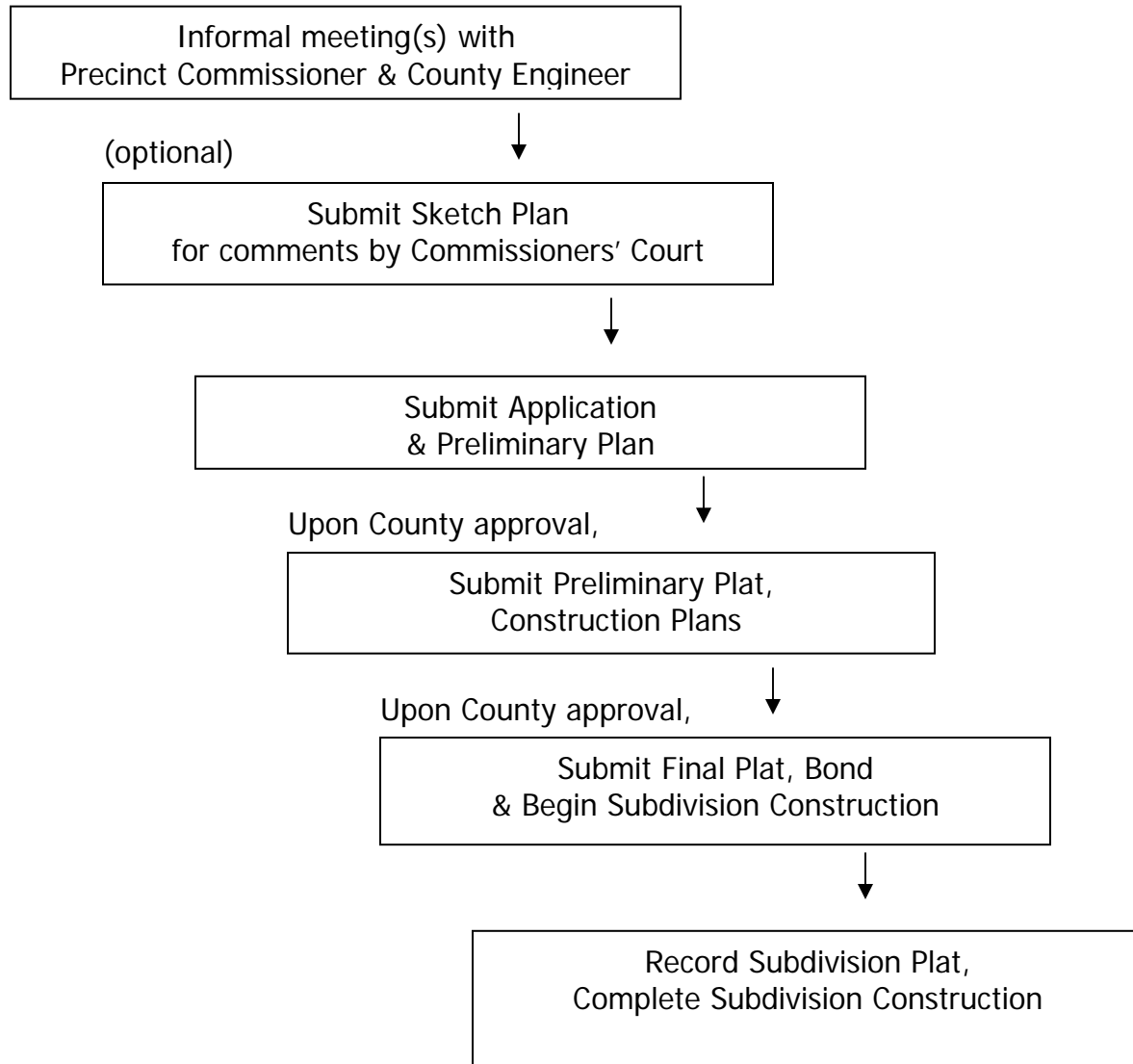

# **APPENDIX L**

## **Regulatory and Permitting Fees**

Current land development fee schedule is available at the office of the County Engineer

Appendix L-1

*Subdivision and Land Development*

*Rules and Regulations*

NOTICE

STATE OF TEXAS           §  
  §  
COUNTY OF BANDERA   §

BEFORE ME, the undersigned authority, on this day personally appeared \_\_\_\_\_, who after being by me duly sworn, stated:

“I am the County Engineer for Bandera County, Texas. The property described in the attached Exhibit A is deemed an “Under-sized lot”, and is recorded at Vol \_\_\_\_\_ page \_\_\_\_\_ of the Plat Records of Bandera County, Texas. The Subdivision which contains the Under-sized lot has been approved by the Commissioners’ Court of Bandera County, Texas under Article 8.1.5 of the Bandera County Subdivision Land Development Rules and Regulations. Notice is hereby given that approval of such Subdivision and Under-sized lot was contingent upon the restriction that the Under-sized lot shall be used exclusively for commercial purposes as clarified herein.

The Under-sized lot and any and all Structures located thereon shall be used exclusively for commercial purposes and activities, and in no event shall the Under-sized Lot and/or any Structure on an Under-sized Lot be used for residential purposes as defined herein.

As used herein “residential purposes” is to be given the broadest definition possible and includes without limitation the act by one or more persons of lodging, sleeping, living, abiding or dwelling for a single night or more, inside or outside of a Structure of any type located on the Under-sized lot, regardless of whether there is or is not a charge for such lodging, sleeping, living, abiding or dwelling.

A “building” is any Structure with four walls and a roof regardless of whether it is or is not permanently affixed to the Under-sized lot. “Structure” includes but is not limited to the whole or any part of: a building, anything existing on the Under-sized lot that does not have four walls and a roof, a temporary Structure, a permanent Structure, a trailer of any kind, a mobile home, a modular home and/or a tent. The phrase “a trailer of any kind, a mobile home, a modular home and/or a tent” provides examples of what is intended to be included in the definition of “Structure” and is not intended to exclude any other type of structure that would otherwise fall within the given definition.

For further clarification, transient lodging, the occupancy, lease or rental of any Structure on an Under-sized lot for residential purposes, as defined herein, and/or the use of an Under-sized lot and any Structure located thereon for an apartment, a tourist court, a trailer park, an inn, a lodging house, a rooming house, a bed and breakfast, a motel and/or a hotel is deemed a residential use or purpose. Such use of an Under-sized lot and any Structure located thereon is not allowed but specifically prohibited. A violation of this prohibition shall be subject to enforcement as provided in the Bandera County Subdivision Land Development Rules and Regulations.

The restriction of the use of the Under-size lot to commercial purposes as clarified above shall be a covenant running with the land, and all future assignments, conveyances and/or transfers of the Under-sized lot or any part of the Under-sized lot, whether by itself or as part of another portion of property, shall be subject to such commercial use only restriction.

---

Dieter Werner, P.E.  
County Engineer for Bandera  
County, Texas

STATE OF TEXAS           §  
  §  
COUNTY OF \_\_\_\_\_ §

This instrument was acknowledged before me on this \_\_\_\_ day of \_\_\_\_\_, 20\_\_\_\_  
by \_\_\_\_\_, as and under his authority as County Engineer for  
Bandera County, Texas.

---

Notary Public, State of Texas